

MANUALE D'USO E ISTRUZIONI DI MONTAGGIO

USER MANUAL AND ASSEMBLY INSTRUCTIONS

MANUEL D'UTILISATION ET INSTRUCTIONS DE MONTAGE

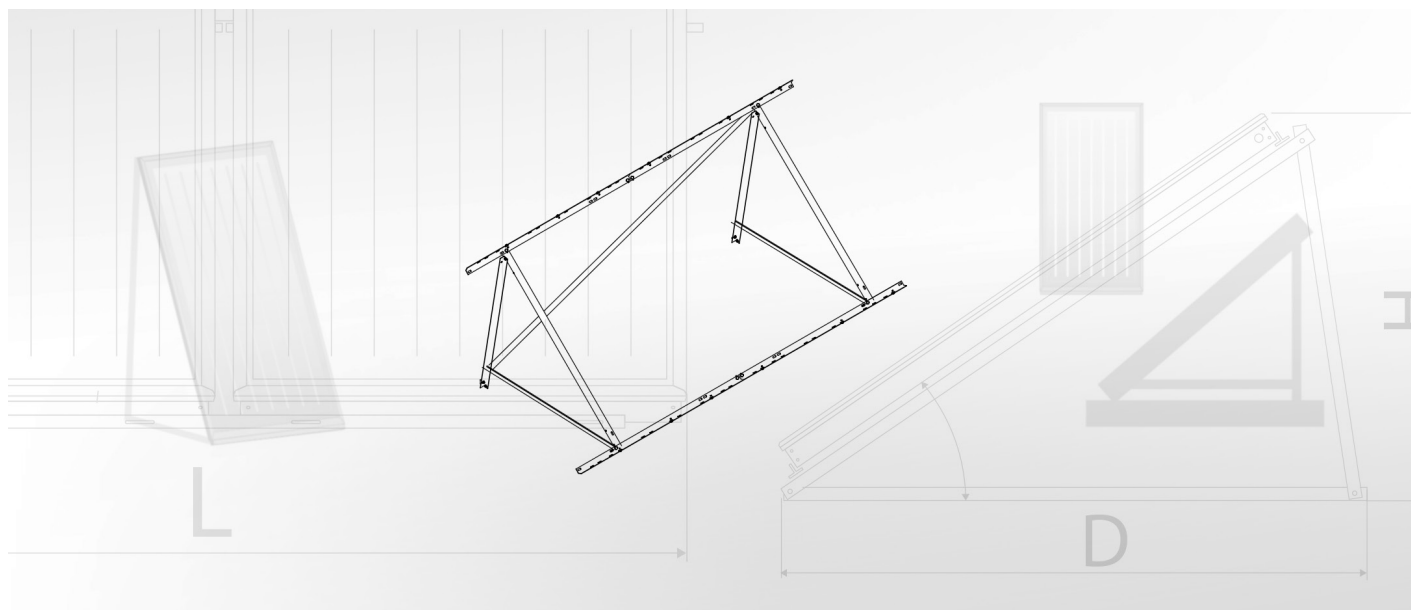

Kit carpenteria tetto piano per sistemi a circolazione forzata
Flat roof supporting and mounting structure kit for forced circulation systems
Kit charpente toit plat pour systèmes à circulation forcée

IT - Manuale d'uso e istruzioni di montaggio	3
EN - User manual and assembly instructions	7
FR - Manuel d'utilisation et instructions de montage.....	11
Annex/Appendice	19

Manuale d'uso e istruzioni di montaggio

1. Generalità

Il presente documento è destinato all'installatore ed all'utilizzatore finale. Pertanto dopo l'installazione e l'avvio dell'impianto occorre assicurarsi che esso sia consegnato all'utilizzatore finale o al responsabile della gestione dell'impianto. Il costruttore declina ogni responsabilità per danni derivanti dalla mancata osservanza delle presenti istruzioni e di quelle contenute in eventuali documenti integrativi consegnati con il sistema.

Le strutture di sostegno dei sistemi solari Cordivari sono destinate unicamente al fissaggio di sistemi solari Cordivari. Qualsiasi utilizzo difforme o il non rispetto delle indicazioni contenute nel presente documento sollevano il costruttore da ogni responsabilità e comportano il decadimento di ogni forma di garanzia.

1.1 Simboli utilizzati



Pericolo generico



Tensione elettrica pericolosa



Pericolo di caduta con dislivello



Pericolo da carichi sospesi



Protezione obbligatoria degli occhi



Obbligo di indossare il casco protettivo



Obbligo di indossare calzature protettive



Obbligo di indossare guanti di protezione



Obbligo di indossare protezione individuale contro le cadute



Informazioni inerenti il contesto

2. Norme

- UNI EN ISO 9488:2022 - Energia solare – Vocabolario
- UNI EN 12975:2022 - Collettori solari - Requisiti generali
- UNI EN 1991:2004 parti 1-2, 1-3 e 1-4 – Azioni sulle strutture, carichi di neve e carichi del vento

3. Strutture di sostegno

Le strutture di sostegno dei sistemi solari Cordivari sono realizzate in profilati di acciaio al carbonio protetti da un particolare rivestimento

anticorrosivo a garanzia di resistenza e durata nel tempo. Le strutture vengono fornite sotto forma di componenti smontati da assemblare sul posto mediante bullonatura.

4. Montaggio kit carpenteria



Pericolo in caso di vento

I collettori solari presentano un'ampia superficie esposta al vento, pertanto evitare di svolgere le operazioni di montaggio in presenza di vento forte.

Si raccomanda di seguire le prescrizioni citate dalle normative riguardo l'azione degli agenti atmosferici ed in particolare l'azione del vento e del carico di neve. Rispettare le limitazioni e le indicazioni illustrate nel paragrafo successivo.



Pericolo di caduta

Il montaggio di impianti solari comporta molto spesso la necessità di operare su tetti o solai con conseguenti pericoli di cadute. In queste condizioni occorre attenersi alle vigenti disposizioni in materia di sicurezza. In particolare predisporre adeguati sistemi anticaduta e di protezione.



Nel caso in cui non fossero disponibili sistemi di protezione anticaduta, utilizzare adeguati sistemi di imbragatura individuale.



Pericolo di carichi sospesi

Nel sollevare i materiali con l'ausilio di gru o sistemi simili mettere in atto tutte le raccomandazioni e le norme inerenti questo tipo di operazione. In particolare utilizzare mezzi di sollevamento idonei e delimitare la zona di manovra in modo da eliminare rischi di lesioni derivanti dall'eventuale caduta di carichi sospesi.

4.1 Luogo e posizione di installazione

- Preferibilmente orientare il/i collettore/i verso Sud tenendo presente che, in ogni caso orientamenti Sud-Est o Sud-Ovest garantiscono in ogni caso un funzionamento soddisfacente del sistema.
- Sui tetti piani, ove possibile, posizionare il sistema ad una distanza di 1-2 metri dal bordo in modo da limitare l'azione di venti forti.
- Una volta scelto il luogo di installazione, prima di procedere al montaggio, verificare che la struttura del tetto sia in grado di sopportare il carico generato dal sistema solare, irrigidire opportunamente con traverse e correnti coperture in legno in corrispondenza degli appoggi.



In caso di installazione in località soggette a forti nevicate, si raccomanda di adottare idonee misure affinché non si accumulino un elevato quantitativo di neve sui pannelli.



In ogni caso il kit carpenteria non è idoneo per l'installazione in zone dove è previsto che vengano superati i limiti di seguito indicati.

Limite massimo velocità del vento	110 Km/h
Limite massimo carico di neve	1,2 kN/m ²

Per installazioni per cui è previsto il superamento dei suddetti limiti è necessario realizzare degli idonei sistemi di supporto e fissaggio aggiuntivi, a cura e di responsabilità dell'installatore.



Il costruttore declina ogni responsabilità e vincolo di garanzia per sistemi di supporto e fissaggio diversi da quelli forniti.

4.2 Montaggio struttura di sostegno

Ogni Kit Carpenteria Cordivari viene fornito completo di bulloneria e profili in acciaio per la corretta installazione dei sistemi solari. Per il corretto ancoraggio alla superficie di supporto è necessario munirsi di appositi strumenti (utensili idonei), nonché dei sistemi di fissaggio (quali viti, tasselli, tirafondi e quant'altro).

- Per tutte le installazioni è obbligatorio ancorare le strutture alla superficie di appoggio tramite idonei strumenti di fissaggio (non in dotazione). Il mancato o non idoneo ancoraggio delle strutture alle superfici di appoggio solleva il costruttore da ogni responsabilità e comporta il decadimento di ogni forma di garanzia.

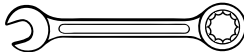
4.2.1. Utensili occorrenti

- | | | |
|---|-----------------------|---|
| 2 | Chiavi fisse da 13 mm |  |
| 1 | Chiavi fisse da 17 mm |  |

4.2.2. Assemblaggio



Obbligo di indossare calzature protettive



Obbligo di indossare guanti di protezione



Obbligo di indossare il casco protettivo

Si consiglia inizialmente di serrare i bulloni a mano e solo a montaggio completato procedere al serraggio tramite chiave

Nel caso di stringhe di collettori posizionate l'una dietro l'altra occorre necessariamente porre l'attenzione al problema delle ombre, nel senso che occorre evitare che i collettori si facciano ombra fra di loro. A tal proposito si tenga presente la seguente tabella che fornisce la distanza minima D fra due stringhe in funzione della latitudine e dell'inclinazione.

D min	Nord Italia	Centro Italia	Sud Italia
	5 m	4,5 m	4 m

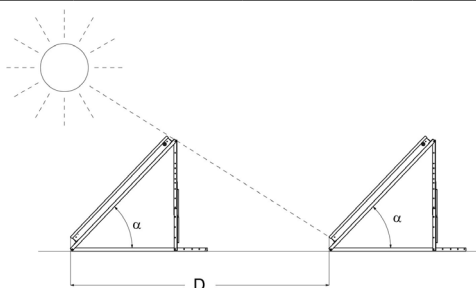

A montaggio ultimato è possibile serrare adeguatamente tutti i bulloni, tranne quelli che fissano le traverse per i quali è opportuno procedere al serraggio solo dopo aver posizionato il/i collettore/i. A questo punto è necessario procedere al fissaggio della struttura alla superficie di appoggio sfruttando i fori realizzati alla base dei componenti. Tale fissaggio può essere, ad esempio, ottenuto con tasselli ad espansione (non forniti) o con analoghi sistemi avendo cura di sigillare il tutto con opportuni prodotti al fine di evitare infiltrazioni d'acqua.

NB: Si raccomanda di assicurarsi che gli angolari di fissaggio a terra della struttura siano completamente appoggiati su una superficie piana (orizzontale o poco inclinata) e di evitare qualsiasi tensione di torsione che potrebbe danneggiare il collettore.

Per collettori solari in numero superiore a 3 il kit di fissaggio sarà costituito da multipli dei sistemi di fissaggio descritti.



Protezione obbligatoria degli occhi nelle operazioni di foratura

4.3 Componenti collegamenti idraulici



CONSULTAZIONE SCHEDA!

Per una corretta installazione del sistema solare, unitamente alla lettura del presente manuale, è necessario consultare il manuale d'uso a corredo del sistema solare e rispettare le indicazioni e le limitazioni in esso contenute.

5. Messa a terra



Come tutte le strutture metalliche, il Kit Carpenteria per sostegno di sistemi solari termici va adeguatamente collegato a terra prima della sua messa in servizio.

6. Manutenzione e ricerca dei guasti

Per il buon funzionamento del kit è necessario effettuare periodicamente i seguenti controlli:

Nei primi 7 giorni di funzionamento dell'impianto

- Controllare il corretto serraggio delle viti della struttura di sostegno.

Una volta all'anno

- Controllare il corretto serraggio delle viti della struttura di sostegno.

7. Smaltimento



Alla fine del ciclo di vita tecnico del prodotto i suoi componenti metallici vanno ceduti ad operatori autorizzati alla raccolta dei materiali metallici finalizzata al riciclaggio mentre i componenti non metallici vanno ceduti ad operatori autorizzati al loro smaltimento. I prodotti devono essere gestiti, se smaltiti dal cliente finale, come assimilabili agli urbani pertanto nel rispetto dei regolamenti del comune di appartenenza. In ogni caso esso non va gestito come un rifiuto domestico.

User manual and assembly instructions

1. General information

This document is intended for the installer and the end user. After the system installation and commissioning make sure it is delivered to the end user or the system manager. The manufacturer is not responsible for damages resulting from failure to follow these instructions and those contained in any additional documents delivered with the system.

The support structures for Cordivari solar systems are designed exclusively for fastening Cordivari solar systems. Any improper use of the product or failure to comply with the instructions contained in this document shall exonerate the manufacturer from any liability and shall likewise void any form of warranty that may apply.

1.1 Symbols used



General hazard



Dangerous electrical voltage



Risk of falling from height



Danger: suspended loads



Mandatory eye protection



A protective helmet must be worn



Protective footwear must be worn



Protective gloves must be worn



Personal protective equipment against falls must be worn



Context information

2. Standards

- UNI EN ISO 9488:2022 - Solar energy - Vocabulary
- UNI EN 12975:2022 - Solar collectors - General requirements
- UNI EN 1991:2004 parts 1-2, 1-3 and 1-4 – Actions on structures, snow loads and wind actions

3. Supporting structures

The supporting structures of Cordivari solar systems are made of carbon steel profiles protected by a special anti-corrosive coating to guarantee strength and durability. The structures are supplied in the form of disassembled components, which must be assembled using bolts at the point of installation.

4. Supporting and mounting structure kit assembly



Wind hazard

Solar collectors have a large area exposed to the wind, therefore do not install in case of strong winds.

It is recommended to comply with the regulatory requirements regarding the effects of atmospheric agents, particularly the effects of wind and the maximum snow load. Always respect the limitations and instructions illustrated in the following paragraph.



Danger of falling

The installation of solar energy systems very often requires working on roofs or surfaces with consequent danger of falling. In these conditions safety regulations in force must be complied with. In particular, adequate fall prevention and protection systems should be provided.



If fall protection systems are not available, use suitable individual harness.



Danger due to suspended loads

When lifting materials by means of cranes or similar equipment comply with all relevant recommendations and regulations. In particular, use suitable lifting equipment and delimit the operation areas to eliminate risks of injury from falling of suspended loads.

4.1 Installation location and position

- If possible, position the collector(s) towards the South, bearing in mind that South-east or South-west orientations can both ensure satisfactory system operation.
- For flat roofs, where possible, place the system at a distance of 1-2 metres from the edge so as to limit the action of strong winds.
- After selecting the installation site, and before proceeding with installation, make sure that the roof structure can bear the load generated by the solar energy system. If necessary, reinforce the areas of the roof where the supports will be resting with appropriate ledgers and stringers.



If installed in locations with heavy snow, it is recommended to take appropriate measures to ensure that snow does not accumulate on panels.



In any case the supporting and mounting structure kit is not suitable for installation in areas where the limits below are expected to be exceeded.

Wind speed maximum limit:	110 Km/h
Snow load maximum limit:	1,2 kN/m ²

For installations where the above limits are expected to be exceeded, the installer is required under his/her responsibility to use appropriate additional supporting and mounting systems.

The manufacturer assumes no liability and undertakes no warranty obligations for supporting and mounting systems other than those supplied.

4.2 Supporting structure assembly

Every Cordivari supporting and mounting structure kit comes complete with the bolts and steel section bars necessary for the solar systems' proper installation. Appropriate equipment (suitable tools) and fastening systems (including screws, blocks, log bolts, etc.) must be used to ensure that the system is properly anchored to the support surface.

- For every type of installation, the structures must be anchored to the support surface using suitable fasteners (not supplied). The manufacturer shall bear no responsibility, and every form of warranty shall likewise be void, in the event that the structures are not properly anchored to the support surfaces.

4.2.1 Tools needed

2 Fixed 13 mm wrenches

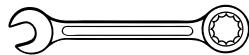

1 Fixed 17 mm wrenches



4.2.2 Assembly



Protective footwear must be worn



Protective gloves must be worn



A protective helmet must be worn

It is advisable to tighten the bolts initially by hand and only after assembly is complete to tighten them using a spanner.

In case of arrays of collectors positioned one behind the other, make sure that collectors do not cast shadows on one another. In this respect, refer to the following table indicating the minimum distance D between two arrays based on latitude and inclination.

Min D	Northern Italy	Central Italy	Southern Italy
	5 m	4.5 m	4 m

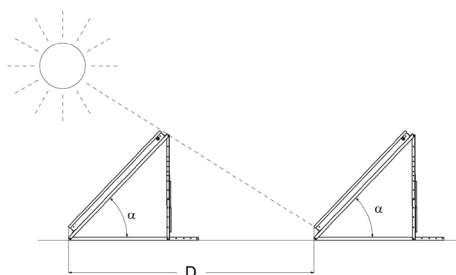

Once the structure's assembly has been completed, all the bolts can be properly tightened except for those that hold the ledgers in place, which should only be tightened after positioning the collector(s).

At this point, the structure must be fixed to the supporting surface using the holes made in the base of components. To secure the structure, for example, expansion plugs (not supplied) or similar equipment can be used, taking care to apply adequate sealants to avoid water infiltration.

NOTE: Make sure that the angle brackets for floor mounting are fully resting on a flat surface (horizontal or slightly inclined) and avoid any torsion stress that might damage the collector.

For more than 3 solar collectors, the mounting structure kit will include multiple quantities of the described fastening systems.



Eye protection required in drilling operations

4.3 Hydraulic connection components



ALWAYS REFER TO THE DATA SHEET!

In order to properly install the solar system, in addition to reading this manual, it is also necessary to consult the user manual provided along with the solar system, and to respect the instructions and limitations contained therein.

5. Grounding



Like all metal structures, the solar thermal system supporting and mounting structure kit must be properly grounded prior to commissioning.

6. Maintenance and troubleshooting

In order to ensure the kit's proper operation, the following periodic checks must be performed:

In the first 7 days of system operation

- Check the proper tightening of the supporting structure's screws.

Once a year

- Check the proper tightening of the supporting structure's screws.

7. Disposal



At the end of the product life-cycle its metallic components should be handed over to operators authorised to collect metallic materials for recycling purposes, while non-metallic components should be handed over to operators authorised to dispose of them.

If disposed of by the end customer, the products must be managed as urban waste and therefore in compliance with the municipal regulations of the relevant municipality. In any case they should not be managed as household waste.

Manuel d'utilisation et instructions

1. Généralités

Cette notice est destinée à l'installateur et à l'utilisateur final. Après l'installation et la mise en service du système il faut donc s'assurer que cette notice est livrée à l'utilisateur final ou au responsable de la gestion du système. Le constructeur décline toute responsabilité pour des dommages résultant de l'observation des instructions fournies dans cette notice et de celles contenues dans tout autre éventuel document complémentaire livré avec le système.

Les structures portantes des systèmes solaires Cordivari sont exclusivement destinées à la fixation de systèmes solaires Cordivari. Toute utilisation autre que celle indiquée dans le présent document dégage le constructeur de toute responsabilité et comporte l'extinction de toute sorte de garantie.

1.1 Symboles utilisés



Danger générique



Tension électrique dangereuse



Danger de chute avec dénivellée



Danger de charges suspendues



Protection obligatoire des yeux



Port obligatoire du casque de protection



Port obligatoire de chaussures de sécurité



Port obligatoire de gants de protection



Port obligatoire d'équipement de protection individuelle contre les chutes



Informations relatives au contexte

2. Normes

- UNI EN ISO 9488:2022 - Énergie solaire – Vocabulaire
- UNI EN 12975:2022 - Capteurs solaires - Exigences générales
- UNI EN 1991:2004 parties 1-2, 1-3 et 1-4 – Actions sur les structures, charges de neige et charges du vent

3. Structures portantes

Les structures portantes des systèmes solaires Cordivari sont réalisées avec des profilés en acier au carbone protégé par un revêtement spécial anticorrosion, pour garantir résistance et durabilité. Les structures sont fournies démontées et doivent être assemblées sur place par boulonnage.

4. Montage kit charpente



Danger en cas de vent

Du fait que les capteurs solaires présentent une grande surface exposée au vent il faut éviter d'effectuer les opérations de montage en présence de vent fort. Il est recommandé de suivre les prescriptions figurant dans les normes concernant les effets des agents atmosphériques et notamment l'action du vent et de la charge de neige. Respecter les limitations et les indications illustrées dans le paragraphe suivant.



Danger de chute

L'installation de systèmes solaires comporte souvent la nécessité d'opérer sur des toits ou des greniers à risque de chute. Dans ces conditions il faut se conformer aux consignes de sécurité en vigueur. Il faut donc prévoir des systèmes antichute et de protection adéquats.



Au cas où des systèmes de protection antichute ne seraient pas disponibles, utiliser des harnais de sécurité individuels adéquats.



Danger dû aux charges suspendues

Pour le levage du matériel à l'aide d'une grue ou d'un appareil de levage similaire suivre toutes les recommandations et normes relatives à ce type d'opération. Il est conseillé d'utiliser des appareils de levage appropriés et de délimiter la zone de manœuvre afin d'éliminer les risques de lésions résultant de l'éventuelle chute de charges suspendues.

4.1 Lieu et position d'installation

- Orienter préférentiellement le(s) capteur(s) vers le sud en tenant compte que des orientations sud-est ou sud-ouest garantissent en tout cas un bon fonctionnement du système.
- S'agissant de toits plats, positionner si possible le système à une distance de 1-2 mètres du bord de sorte à limiter l'action de vents forts.
- Une fois que l'on a choisi le lieu d'installation, avant de procéder au montage, vérifier que la structure du toit est en mesure de soutenir la charge générée par le système solaire, renforcer dûment par des traverses et des couvertures courantes en bois au niveau des appuis.



S'il y a lieu d'installer le système dans une localité exposée aux risques d'abondantes chutes de neige, il est recommandé de prendre les mesures qui s'imposent pour éviter qu'une quantité de neige élevée s'accumule sur les panneaux.



En tout cas le kit charpente n'est pas approprié à l'installation dans des zones où l'on prévoit un dépassement des limites indiquées ci-après.

Limite maximale de la vitesse du vent	110 Km/h
Limite maximale de la charge de neige	1,2 kN/m ²

Pour les installations dont on prévoit le dépassement des limites susdites l'installateur se chargera de réaliser des systèmes de support et de fixation supplémentaires appropriés.

Le constructeur décline toute responsabilité et obligation de garantie pour des systèmes de support et de fixation autres que ceux fournis.

4.2 Montage structure portante

Chaque kit charpente Cordivari est fourni complet de boulonnerie et profilés en acier pour une installation correcte des systèmes solaires. Pour l'ancrage correct à la surface de support il faut disposer d'outils spécifiques (outils appropriés) de même que des systèmes de fixation (tels que vis, chevilles, tirefonds etc.).

- Il est obligatoire pour toutes les installations d'ancrer les structures à la surface d'appui au moyen des outils de fixation adéquats (non fournis). L'ancrage inadéquat ou non effectué des structures aux surfaces d'appui dégage le constructeur de toute responsabilité et entraîne l'annulation de toute garantie.

4.2.1. Outils nécessaires

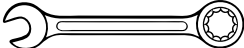
2 Clés fixes de 13 mm 

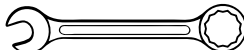
1 Clés fixes de 17 mm 

4.2.2. Assemblage



Port obligatoire de chaussures de sécurité



Port obligatoire de gants de protection



Port obligatoire du casque de protection

Il est conseillé de serrer les boulons à la main dans un premier temps et de ne les serrer à l'aide d'une clé qu'une fois l'assemblage terminé.

En cas de rangées de capteurs placées l'une derrière l'autre, il faut obligatoirement considérer l'ombrage, à savoir il faut éviter que les capteurs ne se fassent mutuellement de l'ombre. À cet égard, se référer au tableau suivant fournissant la distance minimale D entre les deux rangées en fonction de la latitude et de l'inclinaison.

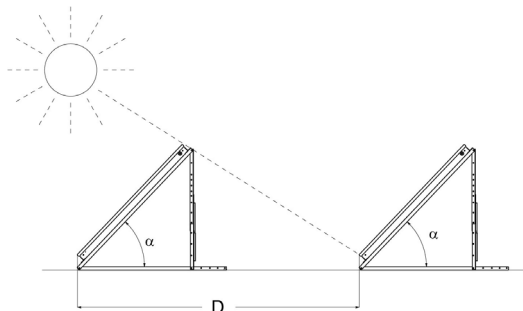

Une fois l'assemblage de la structure terminé, il est possible de serrer dûment tous les boulons, sauf ceux de fixation des traverses dont le serrage convient uniquement après l'emplacement du/des capteur/s.

À ce stade il faut effectuer la fixation de la structure à la surface d'appui en utilisant les trous réalisés à la base des composants. La fixation peut être, par exemple, obtenue avec des chevilles expansibles (non fournies) ou avec des systèmes analogues en ayant soin de sceller le tout avec des produits appropriés afin d'éviter des infiltrations d'eau.

NB: Il est recommandé de vérifier que les cornières de fixation de la structure au sol sont entièrement appuyées sur une surface plate (horizontale ou peu inclinée et d'éviter toute tension de torsion susceptible d'endommager le capteur

En cas d'un nombre de capteurs solaires supérieur à 3, le kit de fixation sera composé des multiples des systèmes de fixation décrits.



Protection obligatoire des yeux pendant les opérations de perçage

4.3 Composants raccords hydrauliques



CONSULTATION FICHE!

Pour l'installation correcte du système solaire, en plus de la lecture de ce manuel, il faut consulter le manuel d'utilisation fourni avec le système solaire et respecter les indications et limitations y reportées.

5. Mise à la terre



Comme toutes les structures métalliques, le Kit Charpente de soutien des systèmes solaires thermiques doit être soigneusement relié à la terre avant sa mise en service.

6. Maintenance et dépiage des pannes

Pour assurer le bon fonctionnement du kit il faut effectuer périodiquement les contrôles indiqués ci-dessous :

Au cours des 7 premiers jours de fonctionnement

- Contrôler le bon serrage des vis de la structure portante.

Une fois par an

- Contrôler le bon serrage des vis de la structure portante.

7. Élimination et mise au rebut

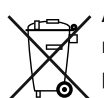

À la fin du cycle de vie technique du produit, ses composants métalliques doivent être remis à des opérateurs autorisés et préposés à la collecte de matériaux métalliques en vue du recyclage, alors que les composants non métalliques doivent être remis à des opérateurs autorisés et préposés à leur élimination. Si les produits sont éliminés par le client final, ils doivent être gérés comme assimilables aux déchets urbains conformément aux règlements de la commune d'appartenance. En tout cas ils ne doivent pas être gérés comme déchets domestiques.

*Annex/appendice

Product: Kit carpenteria per sistemi a circolazione forzata tetto piano verticale
Carpentry kit for forced circulation systems flat roof vertical
Kit de menuiserie pour systèmes de circulation forcée toit plat vertical

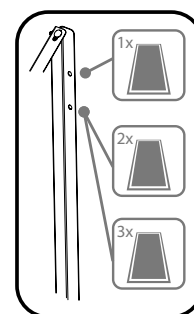
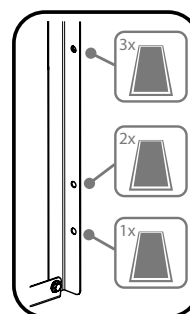
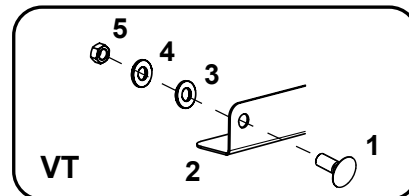
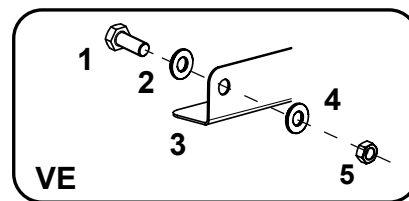
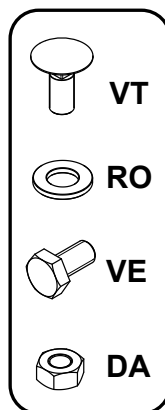
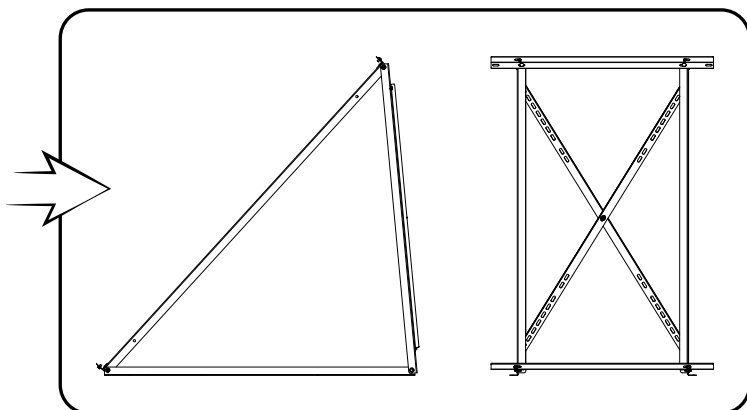

VE M8 X14

*Only for solar panel

*Solo per pannello solare

CF TP 1 COLL.	
2X	(A)
2X	(B) = 2010 mm
4X	(C) = 1500 mm
2X	(D)
4X	VT
30X	RO
15X	VE
15X	DA

CF TP 2 COLL.	
2X	(A)
2X	(B) = 2010 mm
2X	(C) = 1500 mm
2X	(D)
4X	VT
34X	RO
19X	VE
15X	DA

CF TP 3 COLL.	
4X	(A)
3X	(B) = 2010 mm
6X	(C) = 1500 mm
2X	(D)
6X	VT
42X	RO
24X	VE
18X	DA

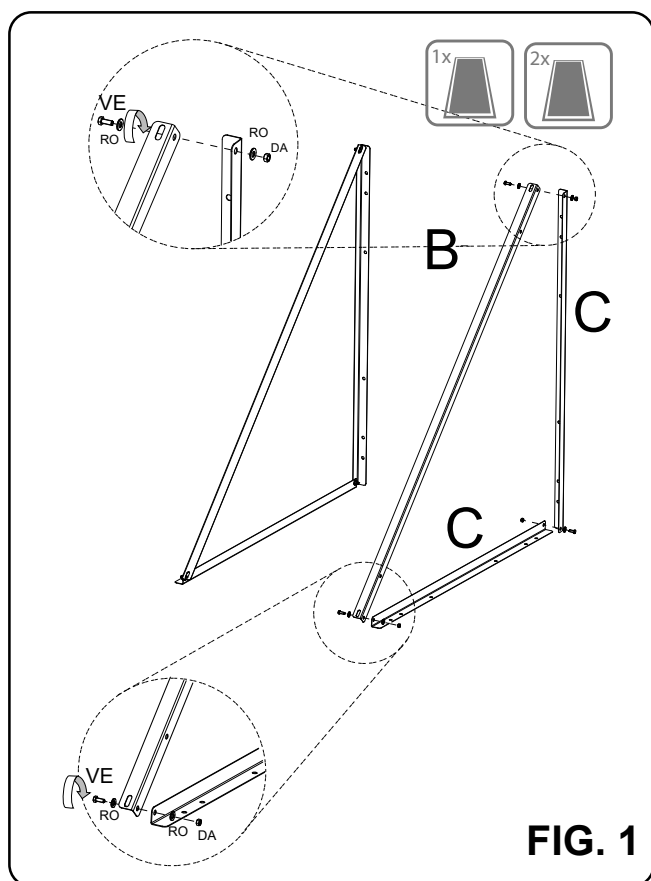

FIG. 1

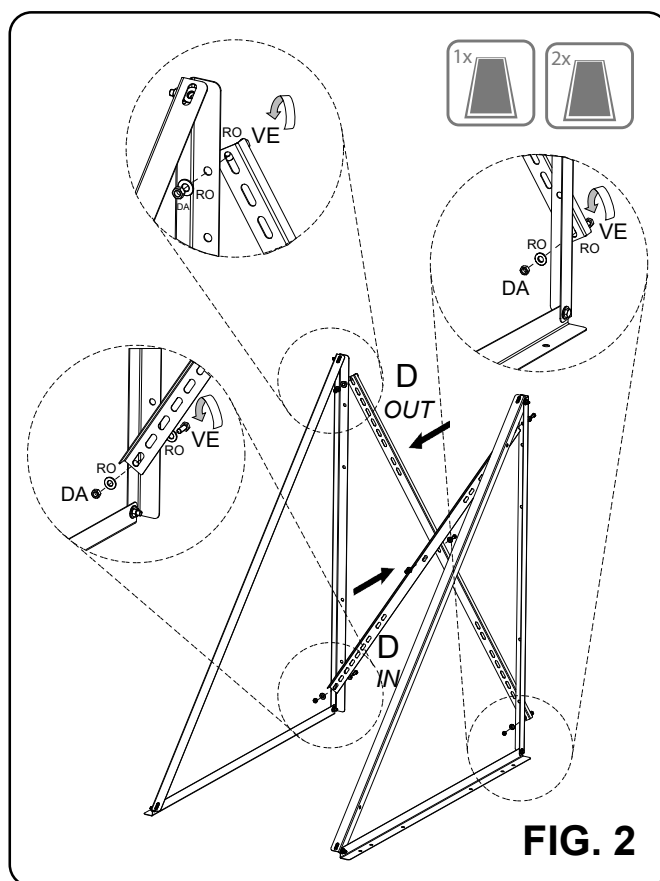
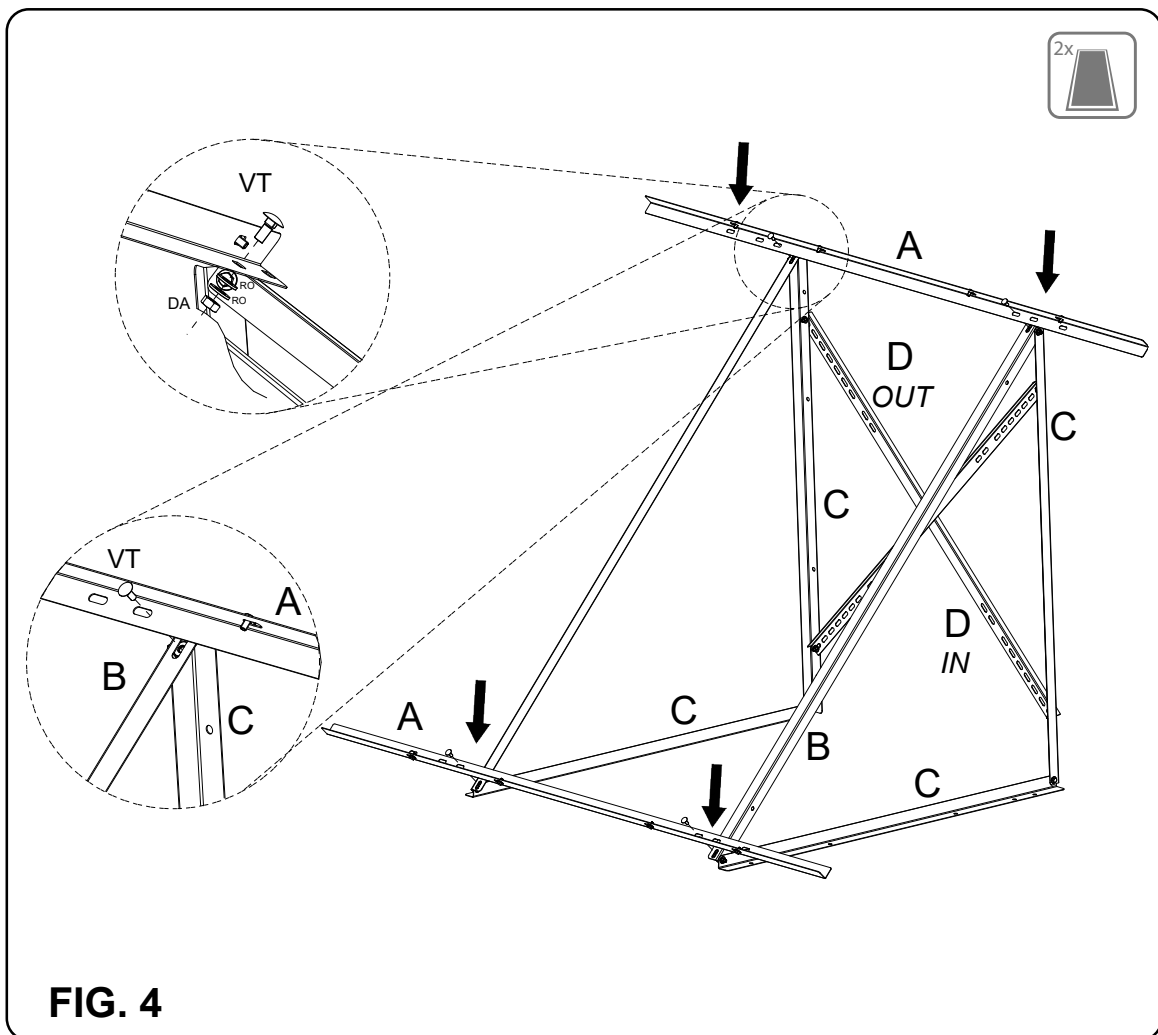
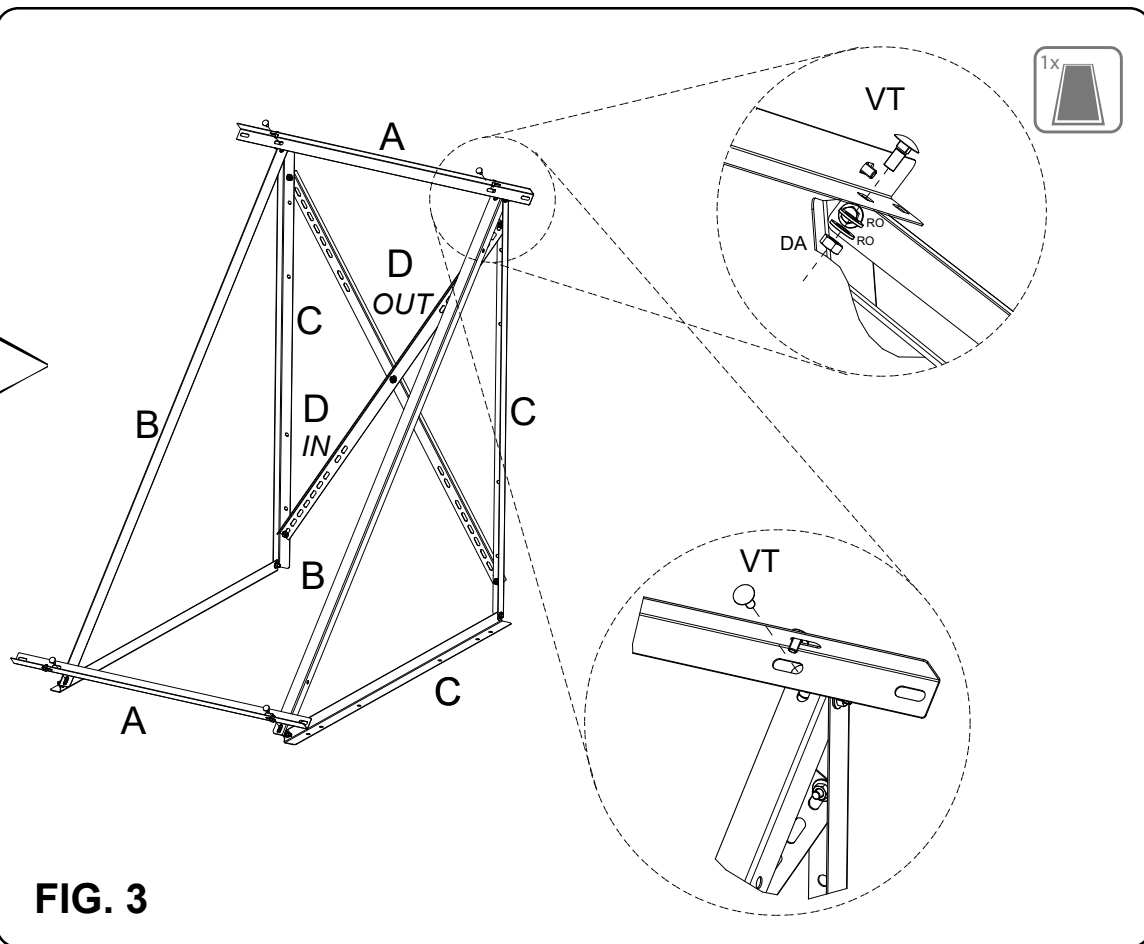
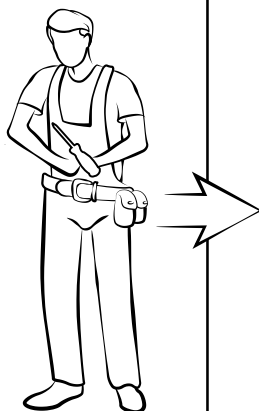

FIG. 2



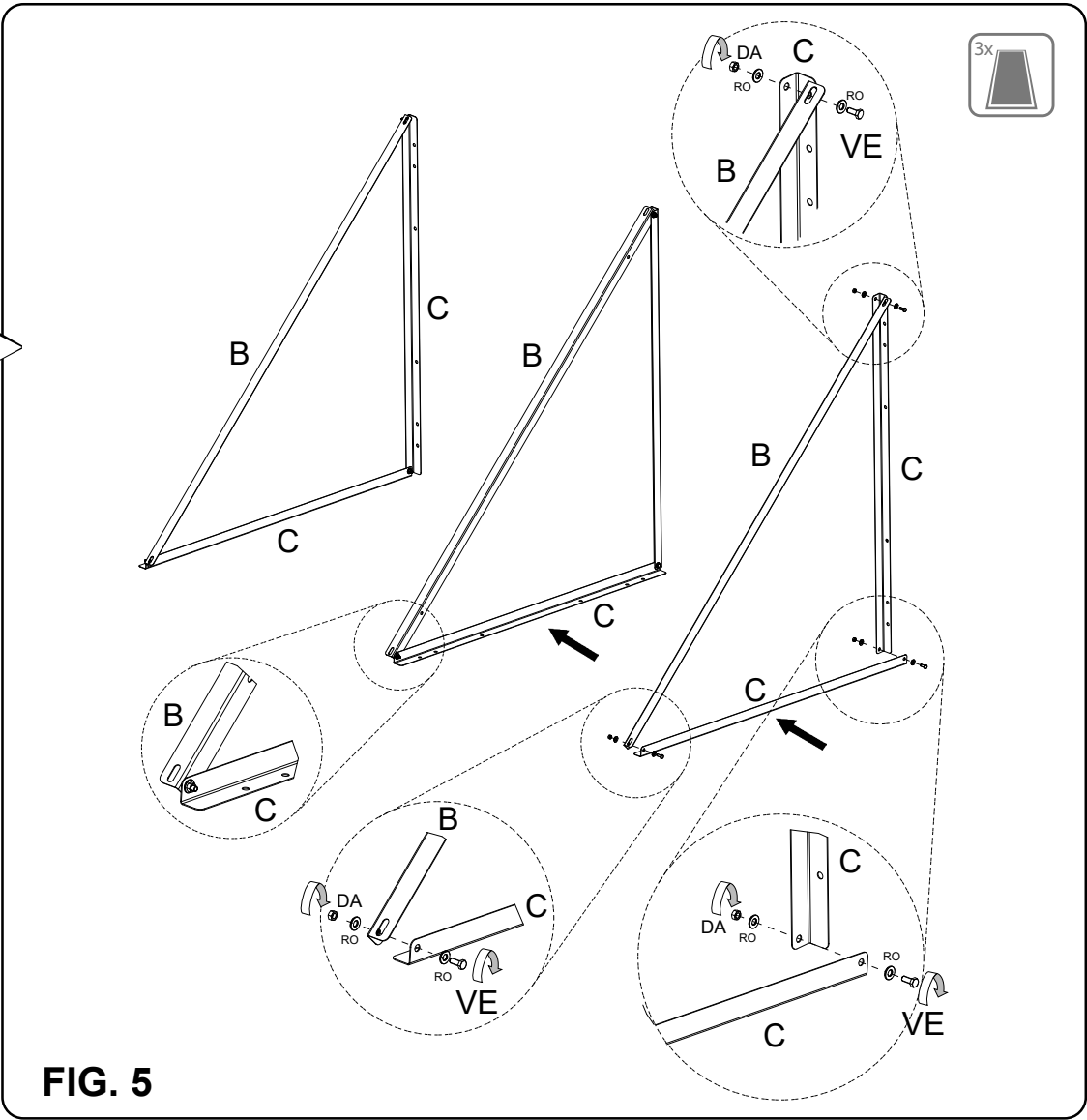
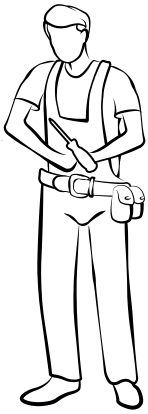

FIG. 5

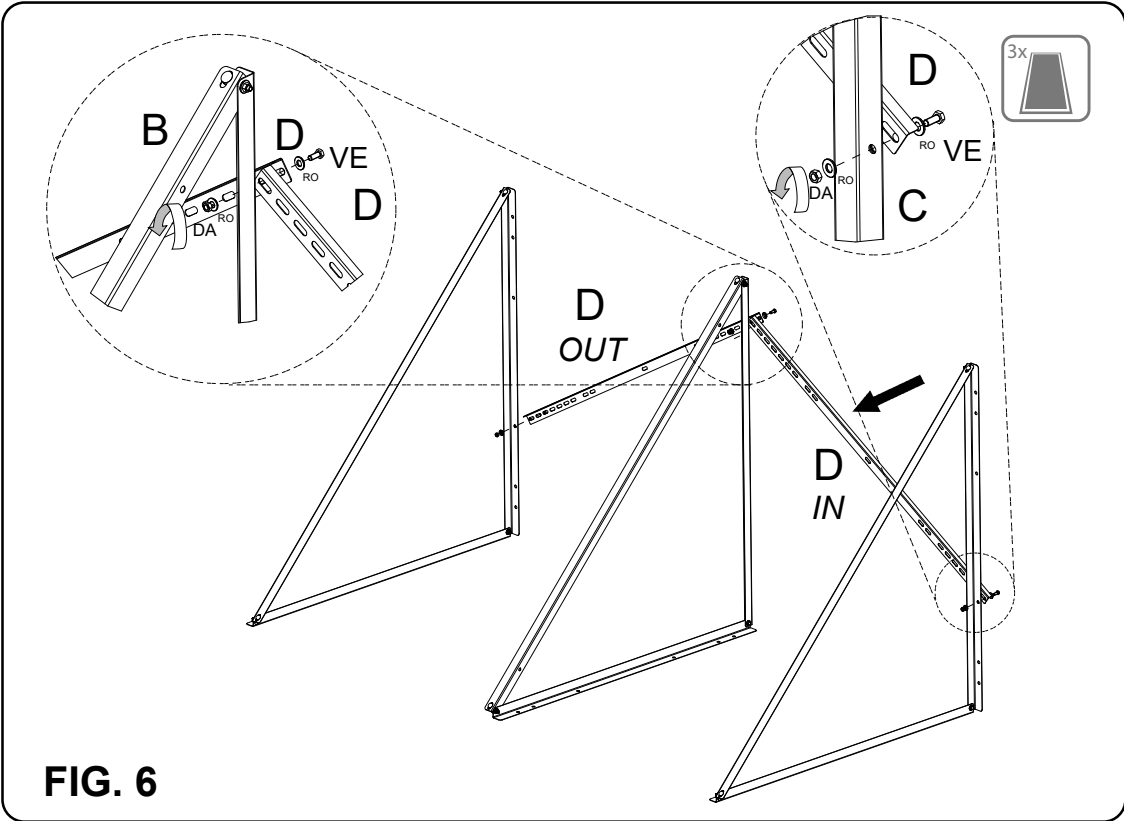

FIG. 6

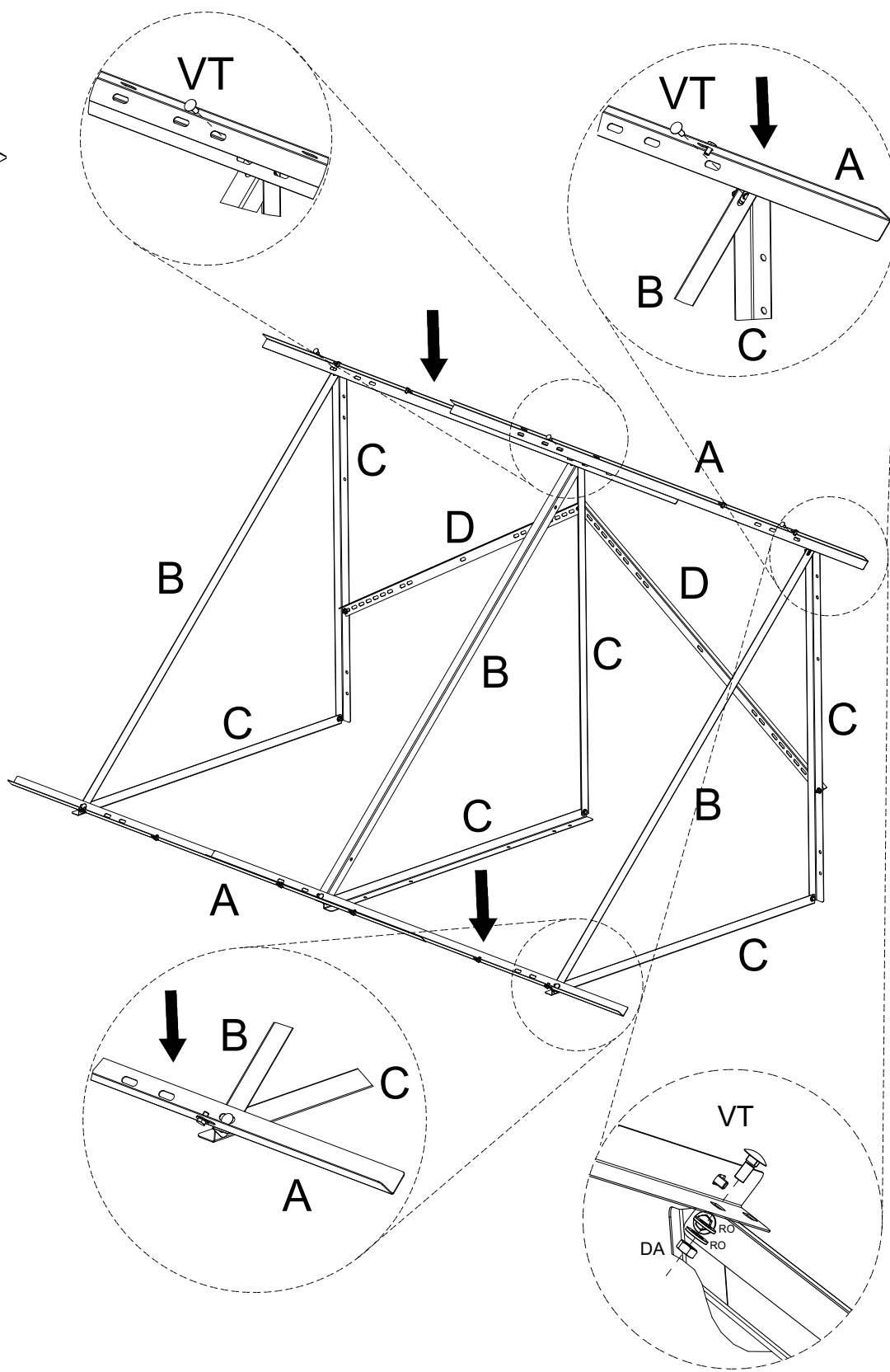
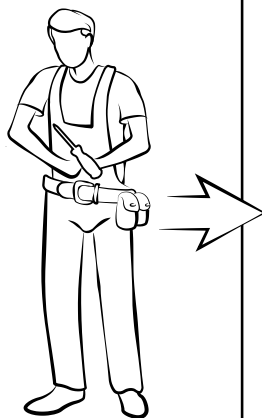

FIG. 7



CORDIVARI®

CORDIVARI S.r.l.
Zona Industriale Pagliare
64020 Morro D'Oro (TE) Italia
cordivari.com
cordivari.design.com
Tel. +39 08580401
Fax +39 0858041418
C.F.-P.IVA-VAT Id nr.
IT00735570673
REA TE Nr. 92310
Cap. Sociale €10.000000,00 i.v.
UNI EN ISO 9001
UNI EN ISO 14001

