

EXTRA 3 WX

POLYWARM® COATED CALORIFIERS WITH 3 EXTRACTABLE STAINLESS STEEL HEAT EXCHANGERS



APPLICATION

Production and storage of domestic hot water (DHW).

MATERIAL

Mild steel Polywarm® coated (Attestation ACS - SSICA - EN 16421 - WRAS).

HEAT EXCHANGER:

N° 3 Stainless steel 316L heat exchangers (upper and middle: straight - lower: Antilegionella® with tubes bent to the bottom)

INSULATION

- SOFT: NOFIRE® polyester fleece 100% made of recyclable material, with high thermal insulation. Fire resistance class B-s2d0 according to EN 13501.

Grey PVC external lining.

CATHODE PROTECTION

n° 2 magnesium anodes.

DRAIN

External confluence through drain pipe.

GASKET- FLANGE PLATE

Silicone gaskets suitable for water intended for human consumption (tested according to 98/83/CE), max temperature up to 200°C. Mild steel exchanger head with anticorrosion treatment.

WARRANTY

5 years (See general sales conditions and warranty)

ACCESSORIES AND SPARE PARTS

See Accessories section for the entire list.

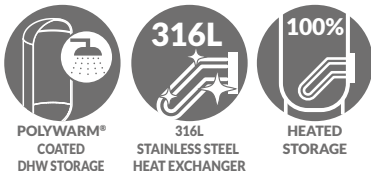

EXTRA 3 WXC

DISMOUNTABLE SOFT FLEECE INSULATION

316L STAINLESS STEEL HEAT EXCHANGERS SURFACE

ENERGY EFFICIENCY CLASS

Model	Art. Nr.	316L STAINLESS STEEL HEAT EXCHANGERS SURFACE			ENERGY EFFICIENCY CLASS
		Lower	Middle	Upper	
1500	3092162360136	3	3	1,5	C
2000	3092162360137	4	4	2	C
3000	3092162360109	6	6	3	
5000	3092162360112	10	10	5	



ACCESSORIES

HEAT MANAGER + electric immersion heater 1,5 kW + probe +3m cable

Art. Nr.	ELECTRIC IMMERSION HEATER
5240000000074	1,5 kW
5240000000075	2 kW
5240000000076	3 kW

See Accessories section

Titanium anode

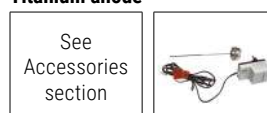

See Accessories section

Thermometer

Art. Nr.
5032240000107
5 units box



EXTRA 3 WX

POLYWARM® COATED CALORIFIERS WITH 3 EXTRACTABLE STAINLESS STEEL HEAT EXCHANGERS

STORAGE		HEAT EXCHANGER	
Pmax	Tmax	Pmax	Tmax
6 bar	90 °C	12 bar	110 °C

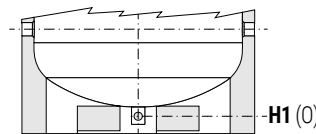
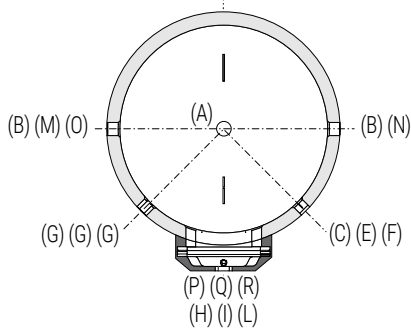
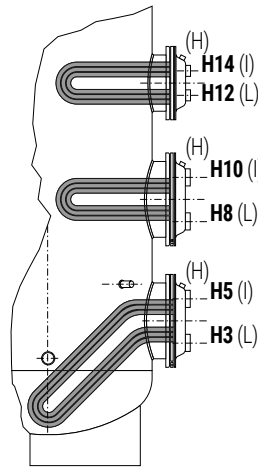
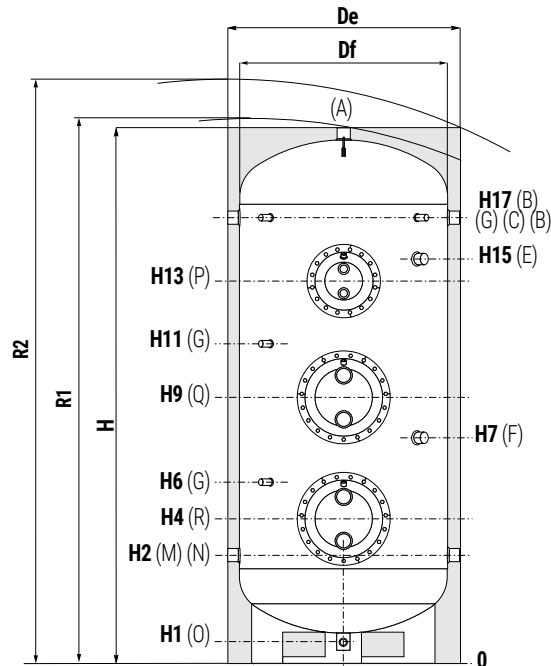
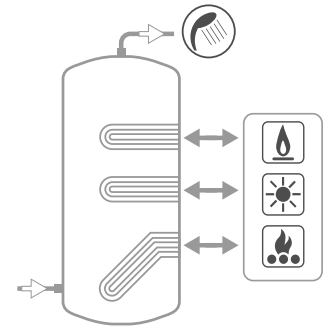

All models are equipped with a practical **skirt** support which facilitate the handling with transpallets and forklifts. Also, discharge piping already mounted to allow **total emptying**.

A	Domestic hot water outlet 2" F
B	Recirculation / Domestic hot water outlet 1 1/2" F For models > 1500 connection 2" F
C-G	Connection for instrumentation 1/2" F
E	Connection for 2nd magnesium anode 1 1/4" F (only for models > 1500)
F	Connection for magnesium anode 1 1/4" F
H	Heat exchanger drain 3/8" G F
I	Primary circuit inlet of the upper exchanger 2" F
L	Primary circuit outlet of the upper exchanger 2" F
M	Domestic cold water circuit inlet 1 1/2" F For models > 1500 connection 2" F
N	Alternative domestic cold water circuit inlet or connection for more tanks in series 1 1/2" F For models > 1500 connection 2" F
O	Drain 1" F
P	Upper heat exchanger flange
Q	Middle heat exchanger flange
R	Lower heat exchanger flange

Model	Volume [lt]	Weight [kg]	De	Df	H	R1	R2	H1	H2	H3	H4	H5	H6	H7	H8
1500	1455	291	1210	950	2440	2495	2730	109	440	585	675	765	825	1075	1160
2000	1991	430	1360	1100	2492	2570	2850	91	467	587	692	797	867	842	1157
3000	2933	557	1350	1250	2811	2950	3130	140	551	731	836	941	1011	1036	1371
5000	4996	882	1700	1600	2915	3130	3380	94	580	750	855	960	1030	1035	1400

Model	H9	H10	H11	H12	H13	H14	H15	H17	Q - R	P
1500	1250	1340	1400	1785	1875	1965	//	2050	Øi300/Øe380	Øi300/Øe380
2000	1262	1367	1437	1727	1817	1907	1592	2057	Øi350/Øe430	Øi300/Øe380
3000	1476	1581	1651	2086	2176	2266	1926	2391	Øi350/Øe430	Øi300/Øe380
5000	1505	1610	1680	2010	2115	2220	1855	2420	Øi350/Øe430	Øi350/Øe430

P.E.D. product designed and produced in conformity to the article 4.3 of directive 2014/68/UE - ErP Ecodesign directive 2009/125/CE

EXTRA 3 WX

HEAT EXCHANGERS TECHNICAL DATA



Cordivari heat exchangers, with tubes bent to the bottom, are able to heat the complete volume in an homogeneous way. Energy storing is therefore improved and ignition time data refer to the complete volume of the tank, while in traditional straight heat exchangers equipped calorifires, a range between 9-17% of the volume remains cold.

UPPER HEAT EXCHANGER

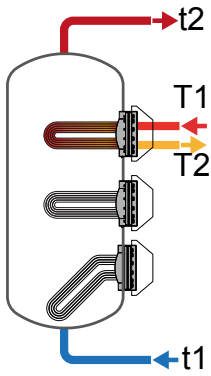

Model	Primary flow rate [m³/h]	Ignition time (minutes) from 10 °C to t2 and primary at T1				Maximum power exchange (kW) with primary at T1, secondary within 10-45 °C and constant use of DHW production				DHW continuous production lt/h within 10-45 °C and primary at T1			
		T1/t2				T1				T1			
		55/50	65/60	70/60	80/60	55	65	70	80	55	65	70	80
1500	6	69	68	48	30	23	37	44	59	571	909	1088	1466
	3	88	89	61	39	19	29	35	46	465	722	855	1137
2000	10	76	77	52	33	33	53	64	86	815	1309	1572	2128
	5	93	94	65	41	28	44	52	69	688	1077	1281	1712
3000	15	63	63	43	27	51	82	98	133	1256	2023	2429	3293
	7,5	77	77	54	34	44	68	81	109	1075	1688	2009	2685
5000	20	81	81	56	35	84	134	160	216	2066	3134	3965	5353
	10	99	100	69	44	71	111	131	174	1755	2734	3244	4314

Model	Primary flow rate [m³/h]	DHW produced in the first 10 minutes in lt/10' input 10 °C output 45 °C, storage at t2 and primary at T1				DHW produced in the first hour in lt/60' input 10 °C output 45 °C, storage at t2 and primary at T1				Heat exchanger pressure drop	
		T1/t2				T1/t2				[mmH ₂ O]	[mbar]
		55/50	65/60	70/60	80/60	55/50	65/60	70/60	80/60		
1500	6	520	683	713	776	882	1259	1402	1704	682	66,9
	3	503	652	674	721	797	1109	1215	1441	179	17,6
2000	10	811	1062	1106	1199	1327	1891	2102	2547	1311	128,6
	5	790	1024	1058	1130	1226	1706	1869	2214	341	33,4
3000	15	1081	1427	1495	1639	1877	2708	3033	3724	2181	213,9
	7,5	1051	1371	1425	1538	1732	2440	2697	3238	560	54,9
5000	20	2152	2282	2921	3152	3461	4367	5432	6542	2314	226,9
	10	2101	2716	2801	2979	3212	4447	4855	5711	592	58,1

MIDDLE HEAT EXCHANGER

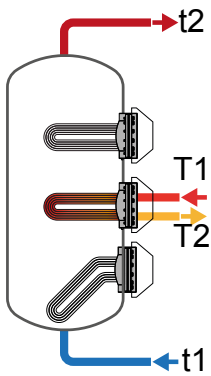

Model	Primary flow rate [m³/h]	Ignition time (minutes) from 10 °C to t2 and primary at T1				Maximum power exchange (kW) with primary at T1, secondary within 10-45 °C and constant use of DHW production				DHW continuous production lt/h within 10-45 °C and primary at T1			
		T1/t2				T1				T1			
		55/50	65/60	70/60	80/60	55	65	70	80	55	65	70	80
1500	15	68	68	47	30	51	82	98	133	1259	2026	2430	3295
	7,5	82	83	57	37	44	68	81	109	1077	1690	2011	2687
2000	20	70	70	48	30	69	111	133	180	1702	2741	3293	4463
	10	84	85	59	37	59	93	111	148	1468	2306	2744	3668
3000	20	71	72	49	31	100	159	190	255	2465	3931	4698	6325
	10	88	89	62	40	84	130	154	204	2086	3229	3821	5057
5000	20	78	78	54	35	162	253	301	400	3998	6275	7459	9924
	10	99	100	71	46	135	204	239	312	3338	5055	5930	7735

Model	Primary flow rate [m³/h]	DHW produced in the first 10 minutes in lt/10' input 10 °C output 45 °C, storage at t2 and primary at T1				DHW produced in the first hour in lt/60' input 10 °C output 45 °C, storage at t2 and primary at T1				Heat exchanger pressure drop	
		T1/t2				T1/t2				[mmH ₂ O]	[mbar]
		55/50	65/60	70/60	80/60	55/50	65/60	70/60	80/60		
1500	15	1149	1512	1579	1723	1947	2795	3118	3810	2181,03	213,9
	7,5	1119	1456	1509	1622	1801	2526	2783	3324	560,28	54,9
2000	20	1595	2095	2187	2382	2672	3831	4273	5209	2846,25	279,1
	10	1556	2023	2096	2250	2485	3483	3834	4573	728,1	71,4
3000	20	2303	3021	3149	3420	3865	5511	6124	7426	2745,34	269,2
	10	2240	2904	3003	3209	3561	4949	5423	6411	700,69	68,7
5000	20	3882	5066	5263	5674	6414	9040	9987	11959	4472,31	438,6
	10	3772	4863	5008	5309	5886	8064	8764	10208	290,29	28,5

EXTRA 3 WX

HEAT EXCHANGERS TECHNICAL DATA



LOWER
HEAT EXCHANGER

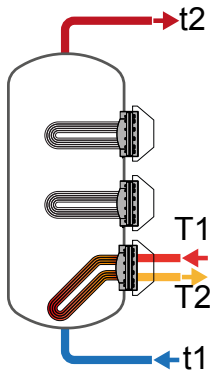

Model	Primary flow rate [m³/h]	Ignition time (minutes) from 10 °C to t2 and primary at T1				Maximum power exchange (kW) with primary at T1, secondary within 10-45 °C and constant use of DHW production				DHW continuous production lt/h within 10-45 °C and primary at T1			
		T1/t2				T1				T1			
		55/50	65/60	70/60	80/60	55	65	70	80	55	65	70	80
1500	15	120	119	82	51	51	81	98	133	1256	2022	2428	3290
	7,5	145	146	100	64	44	68	81	108	1075	1687	2008	2684
2000	20	121	122	83	52	69	111	133	180	1699	2738	3288	4453
	10	146	147	101	65	59	93	111	148	1465	2302	2741	3665
3000	20	128	127	87	55	100	159	190	255	2461	3926	4694	6321
	10	456	157	110	70	84	130	154	204	2082	3224	3817	5053
5000	20	137	138	96	61	162	253	301	401	3992	6270	7450	9921
	10	176	179	125	82	135	204	239	312	3332	5049	5923	7727

Model	Primary flow rate [m³/h]	DHW produced in the first 10 minutes in lt/10' input 10 °C output 45 °C, storage at t2 and primary at T1				DHW produced in the first hour in lt/60' input 10 °C output 45 °C, storage at t2 and primary at T1				Heat exchanger pressure drop	
		T1/t2				T1/t2				[mmH ₂ O]	[mbar]
		55/50	65/60	70/60	80/60	55/50	65/60	70/60	80/60		
1500	15	1855	2394	2462	2605	2651	3675	4000	4689	2295	225,1
	7,5	1825	2338	2392	2504	2506	3407	3664	4204	589,6	57,8
2000	20	2546	3285	3377	3571	3622	5019	5459	6391	2996	293,8
	10	2507	3212	3285	3439	3435	4670	5021	5761	766,42	75,2
3000	20	3748	4827	4955	5226	5307	7314	7928	9230	2836	278,1
	10	3685	4710	4809	5015	5004	6752	7226	8215	723	70,9
5000	20	6362	8166	8363	8775	8891	12137	13081	15058	4707	461,6
	10	6252	7963	8109	8409	8363	11161	11860	13303	1192	116,9

EXAMPLE OF INSTALLATION WITH EXTRA 3

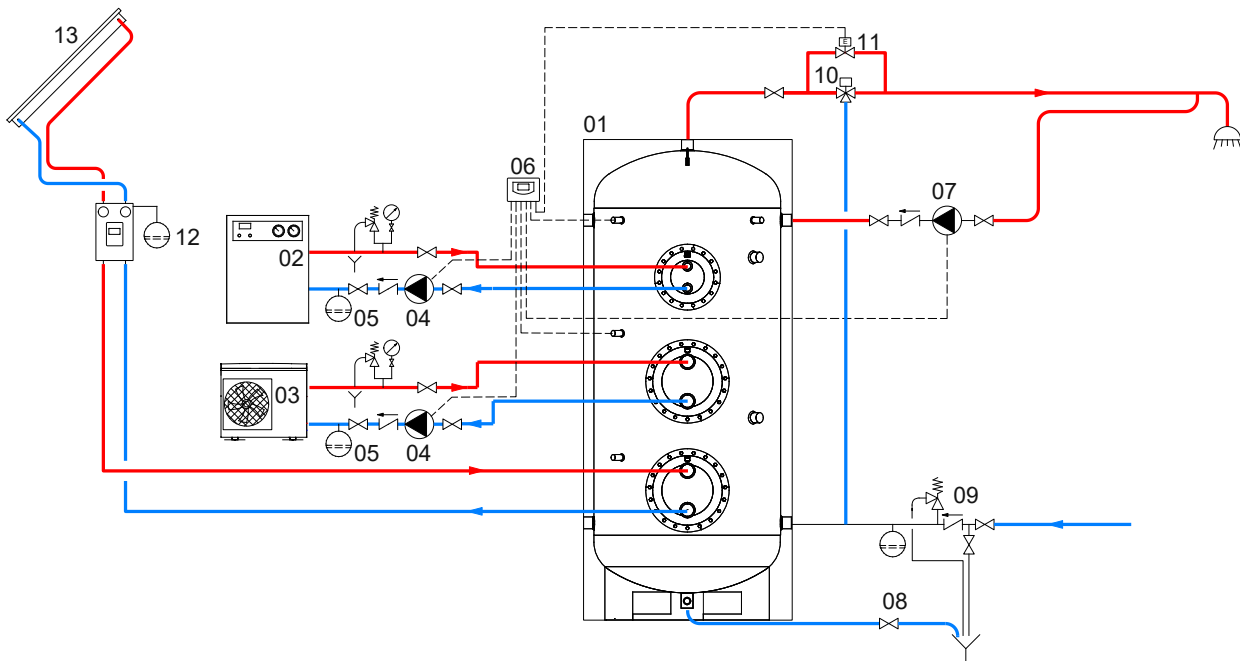

1	Extra 3	5	Expansion vessel	9	Hydraulic safety group	13	Solar panels
2	Generator	6	Electronic Control/thermostat	10	Thermostatic mixing valve		
3	Generator (Heat pump)	7	D.H.W. recirculation group	11	By-pass solenoid valve		
4	Circulation group	8	Blowdown valve	12	Solar system circulation group		

The following schemes are purely illustrative. To realize the installation, always refer to a qualified technician.

EXTRA 3 WX

HEAT EXCHANGERS PRESSURE DROP



Lower heat exchanger surface
[m²]

1500	3
2000	4
3000	6
5000	10

Flow rate [lt/min]

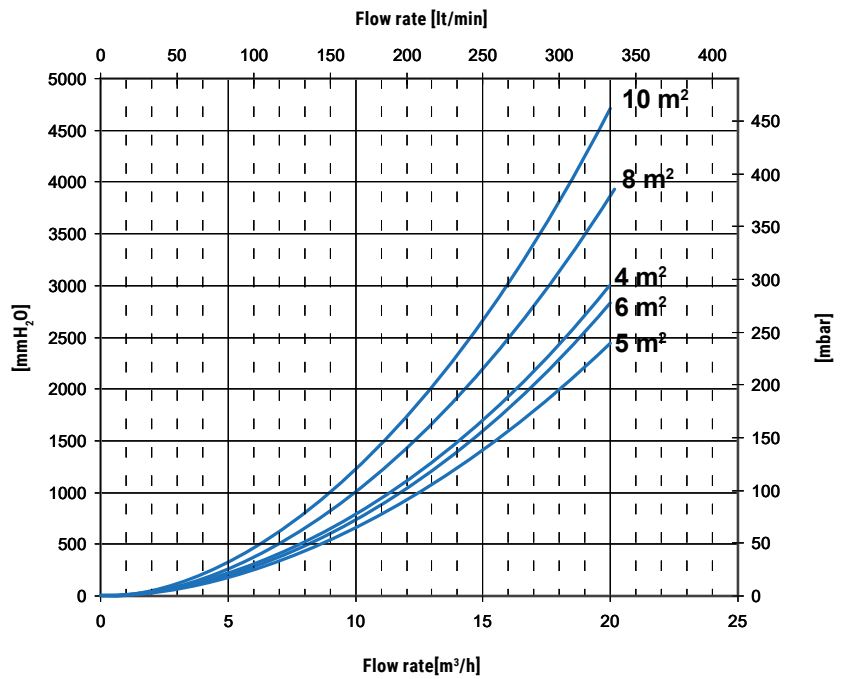
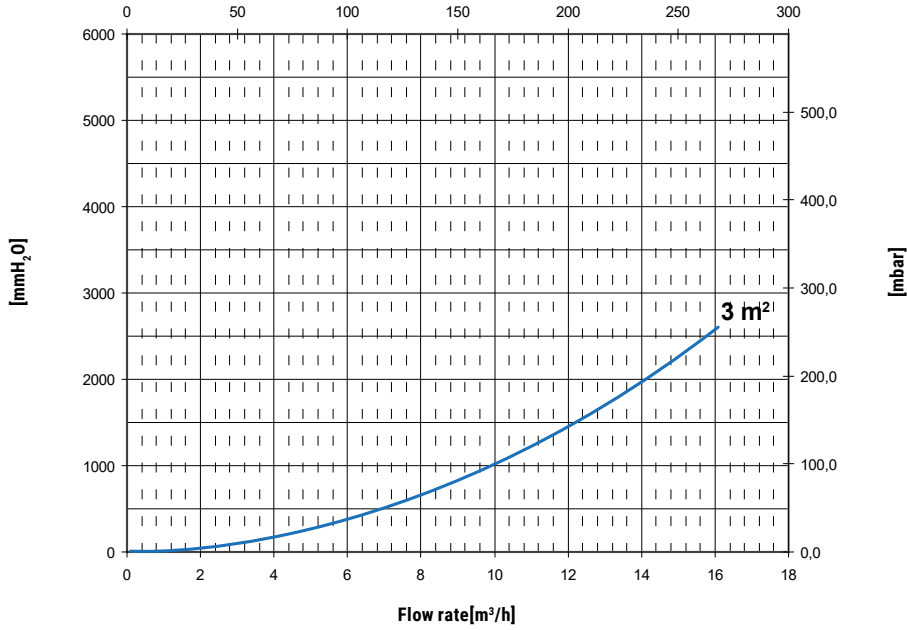

EXTRA 3 WX

HEAT EXCHANGERS PRESSURE DROP



	Heat exchangers surface [m ²]	
	Middle	Upper
1500	3	1,5
2000	4	2
3000	6	3
5000	10	5

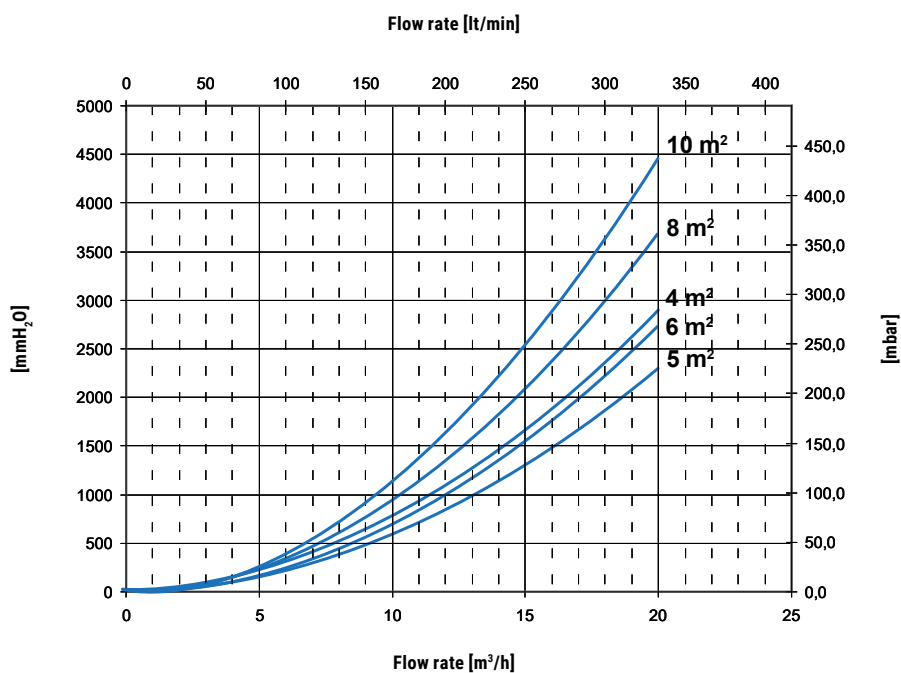
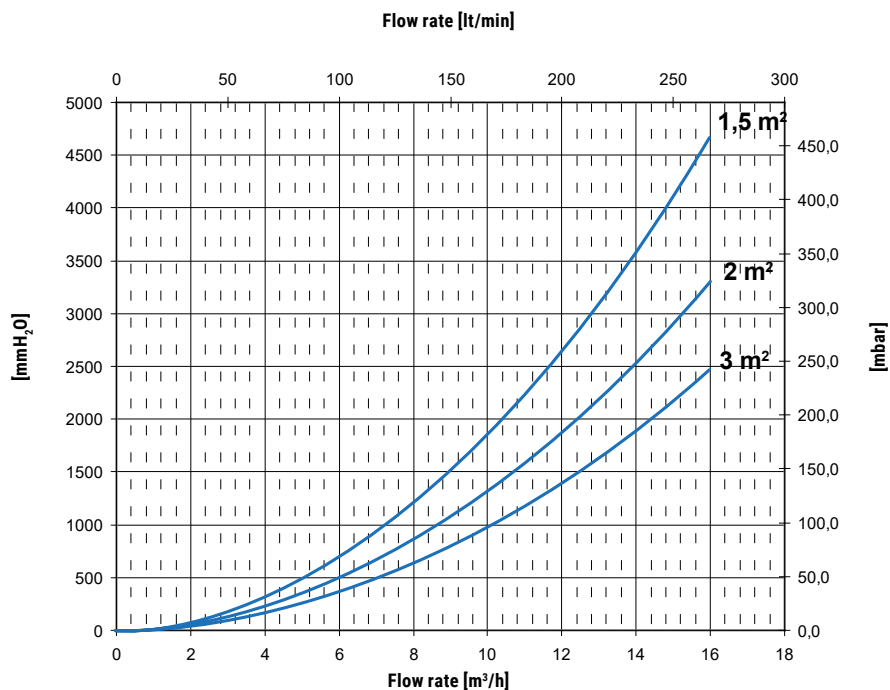

PERFORMANCE CHARTS AT PAGE 82-83

EXTRA 1-2-3 WXC-XXC / EXTRA 1 COMPACT

HEAT EXCHANGERS TECHNICAL DATA

Heat Exchanger output referred to temperature and flow rate of primary circuit and with secondary at 10/45°C at maximum withdrawal of producible DHW (Upper limit of the curves referred to maximum primary flow rate in the heat exchanger, while the lower limit in the curves refer to the minimum primary flow rate)

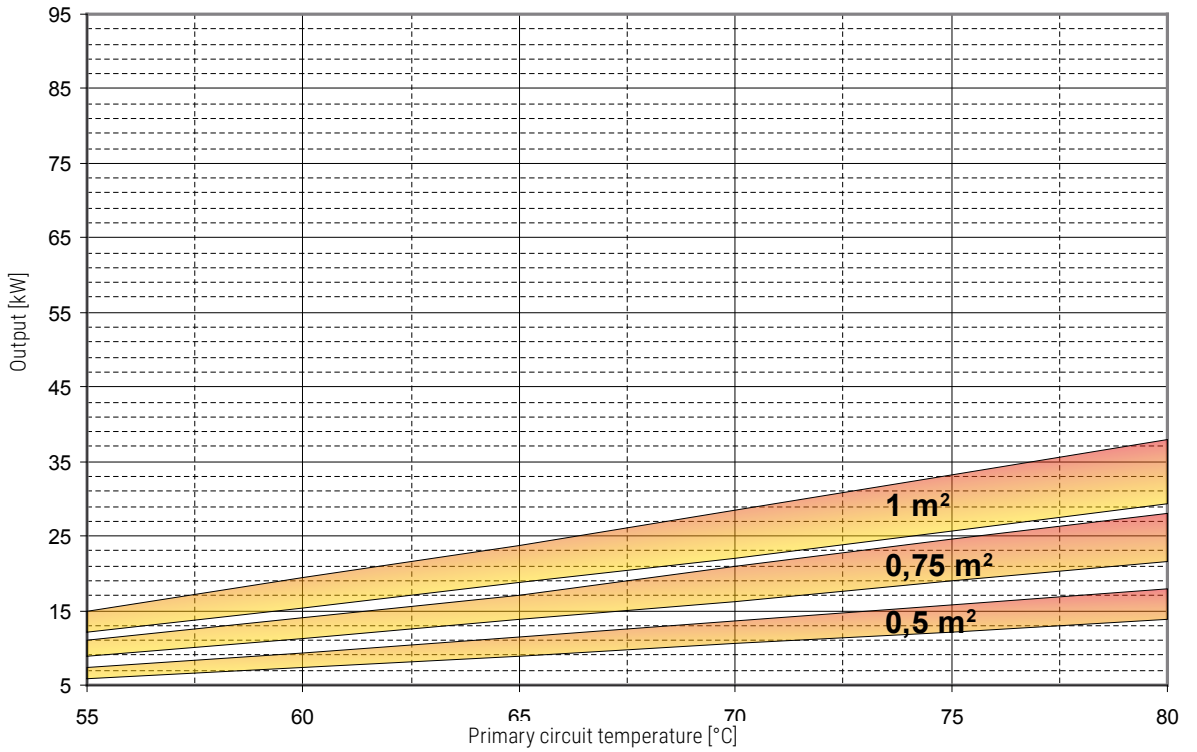
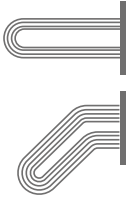

Extractable heat exchanger surface	0,5 m ²		0,75 m ²		1 m ²	
	MAX	MIN	MAX	MIN	MAX	MIN
Flow rate [m ³ /h]	2	1	3	1,5	4	2

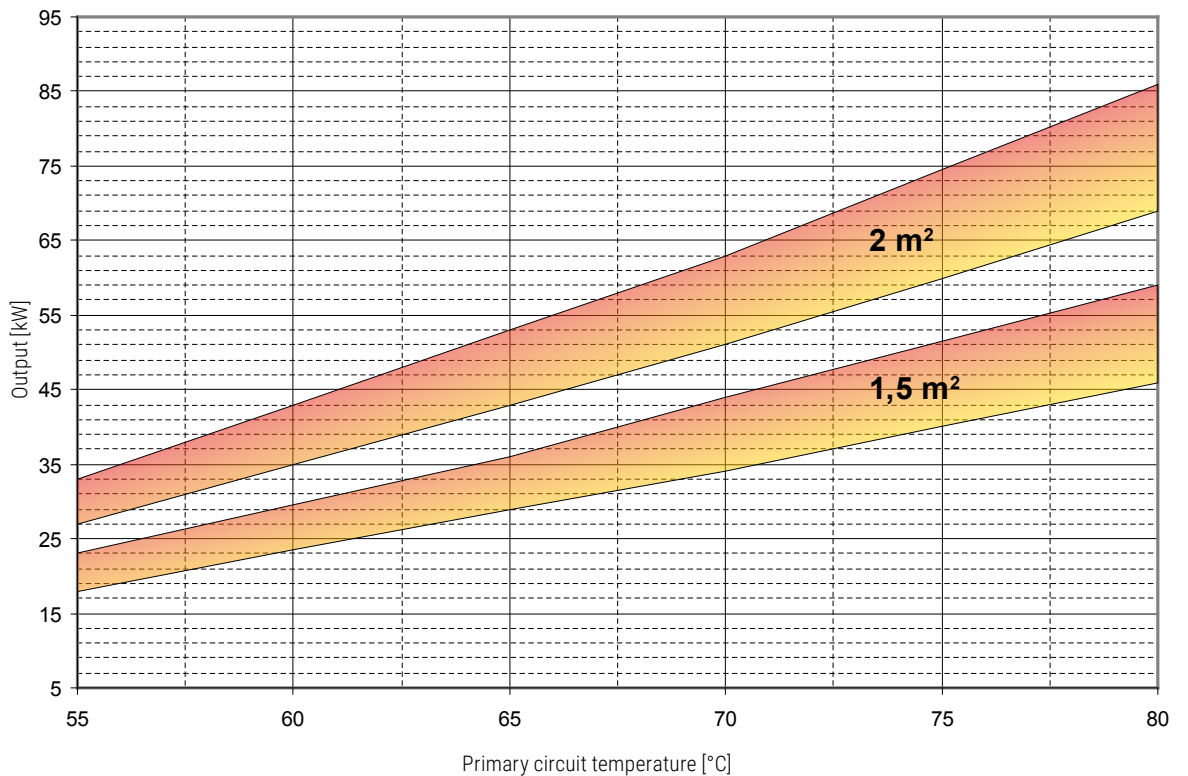
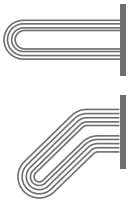

Extractable heat exchanger surface	1,5 m ²		2 m ²	
	MAX	MIN	MAX	MIN
Flow rate [m ³ /h]	6	3	10	5

EXTRA 1-2-3 WXC-XXC / EXTRA 1 COMPACT

HEAT EXCHANGERS TECHNICAL DATA

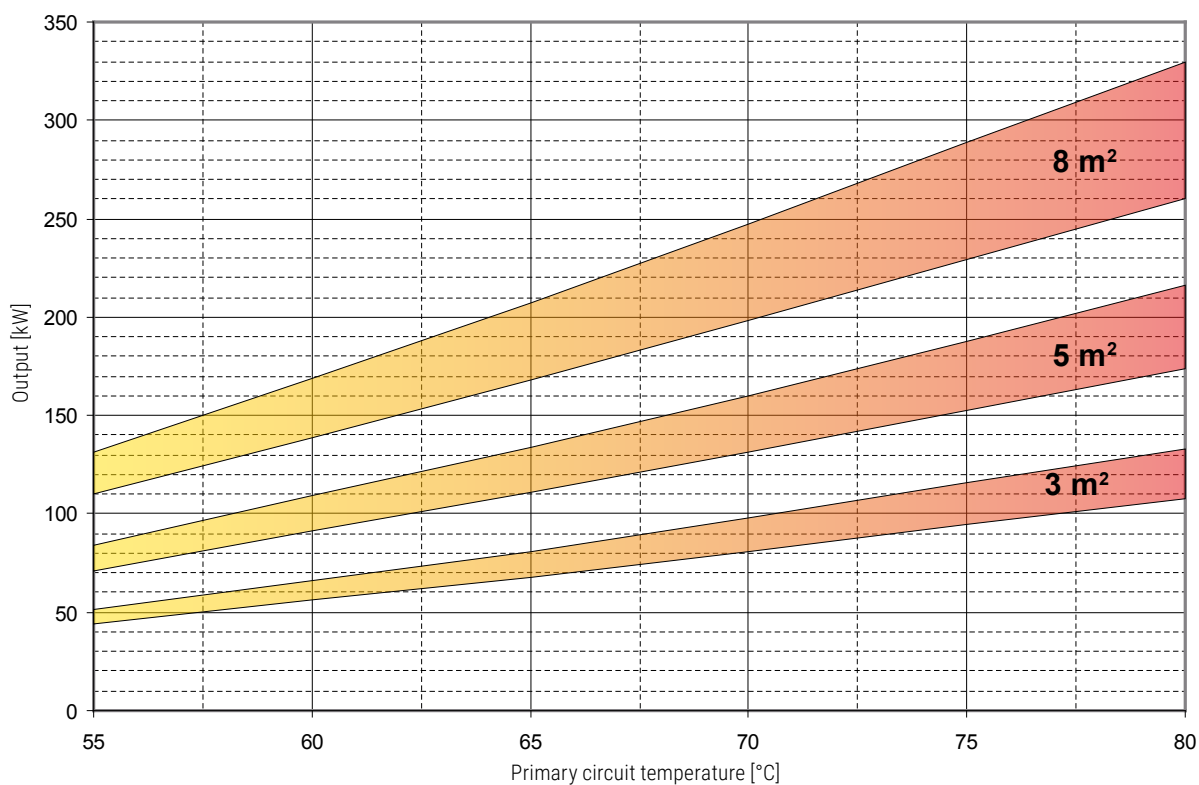

Extractable heat exchanger surface	3 m ²		5 m ²		8 m ²	
	MAX	MIN	MAX	MIN	MAX	MIN
Flow rate [m ³ /h]	15	7,5	20	10	20	10

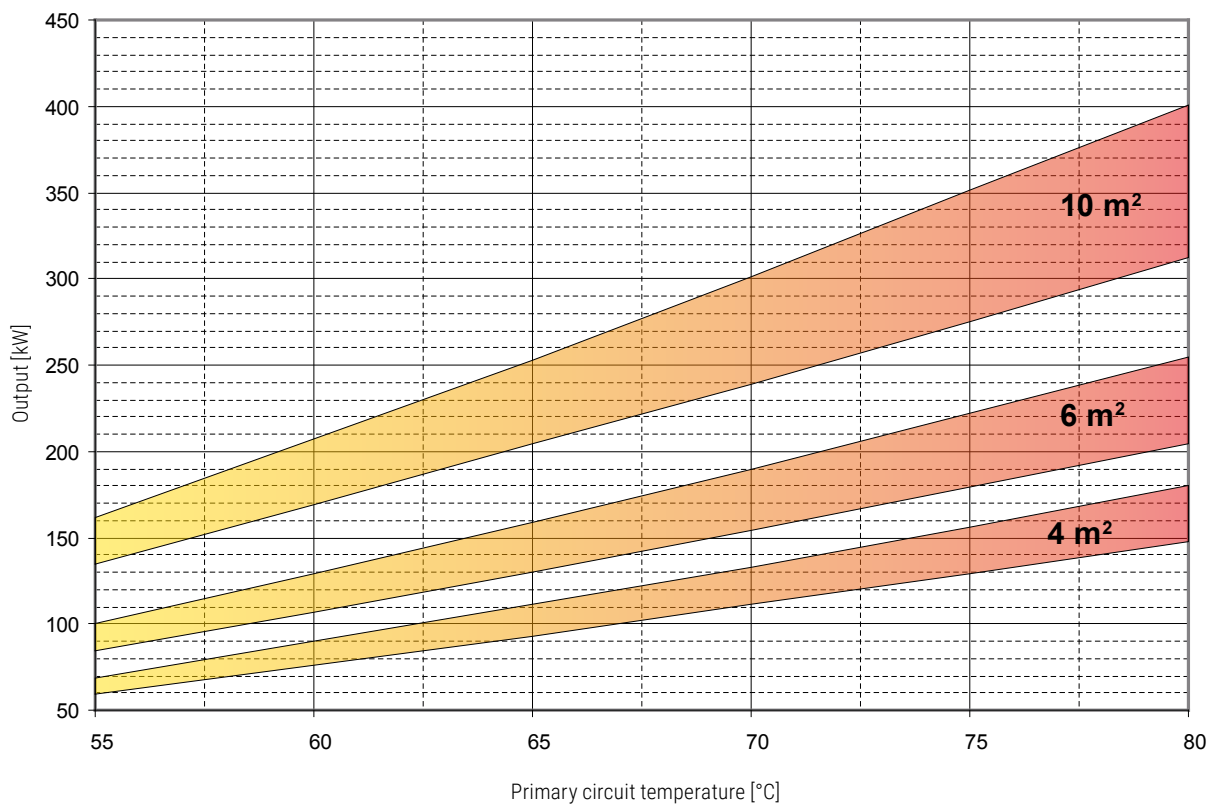

Extractable heat exchanger surface	4 m ²		6 m ²		10 m ²	
	MAX	MIN	MAX	MIN	MAX	MIN
Flow rate [m ³ /h]	20	10	20	10	20	10