

EXTRA 1 INOX

STAINLESS STEEL 316L CALORIFIER WITH 1 EXTRACTABLE STAINLESS STEEL HEAT EXCHANGER



APPLICATION

Production and storage of domestic hot water (DHW).

MATERIAL

Stainless Steel 316 L suitable for domestic hot water

HEAT EXCHANGER:

Stainless steel 316L. Antilegionella® heat exchanger, with tubes bent to the bottom

INSULATION

- HARD: High thermal insulation with ecological polyurethane hard foam.

- SOFT: NOFIRE® polyester fleece 100% made of recyclable material, with high thermal insulation. Fire resistance class B-s2d0 according to EN 13501.

Grey PVC external lining.

CATHODE PROTECTION

Magnesium anode - Models > 1500 n° 2 magnesium anodes.

DRAIN

External confluence through drain connection.

GASKET- FLANGE PLATE

Silicone gaskets suitable for water intended for human consumption (tested according to 98/83/CE); Mild steel exchanger head with anticorrosion treatment.

WARRANTY

5 years (See general sales conditions and warranty)

ACCESSORIES AND SPARE PARTS

See Accessories section for the entire list.

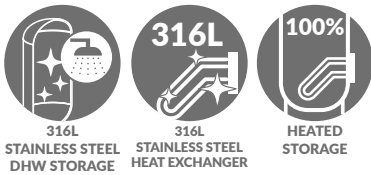

EXTRA 1 XXB

Model	HARD FOAM INSULATION Art. Nr.	HEAT EXCHANGER SURFACE INOX 316L [m²]	ENERGY EFFICIENCY CLASS ErP
200	3072052300422	0,5	B
300	3072052300423	0,75	C
500	3072052300424	1	C



EXTRA 1 XXC

Model	DISMOUNTABLE SOFT FLEECE INSULATION Art. Nr.	HEAT EXCHANGER SURFACE INOX 316L [m²]	ENERGY EFFICIENCY CLASS ErP
800	3072052300430	1,5	C
1000	3072052300435	2	C
1300	3072052300432	3	C
1500	3072052300433	3	C
2000	3072052300434	4	C
2500	3072052300410	5	
3000	3072052300412	6	
4000	3072052300414	8	
5000	3072052300416	10	

ACCESSORIES

ELECTRIC IMMERSION HEATERS

Mod.	MONOPHASE			THREEPHASE				
	1,5 kW	2 kW	3 kW	4 kW	5 kW	6 kW	9 kW	12 kW
	52400000000051	52400000000052	52400000000053	52400000000047	52400000000048	52400000000049	52400000000050	52400000000031
	Ignition time from 10 °C to 45 °C with electric immersion heaters [min]			Ignition time from 10 °C to 45 °C with electric immersion heaters [min]				
200	49	87	65	44	33	//	//	//
300	76	136	102	68	51	//	//	//
500	127	228	171	114	85	68	57	//
800	178	318	239	159	120	96	80	//
1000	243	436	327	218	163	131	109	73
1300	274	450	340	230	194	155	129	86
1500	288	516	387	258	297	238	198	132
2000	443	793	595	396	387	310	258	172
2500	577	1033	775	517	387	310	258	172
3000	577	1033	775	517	535	428	357	238
4000	797	1428	1071	714	699	559	466	311
5000	1040	1864	1398	932	699	559	466	311

Titanium anode (for stainless steel calorifiers)

See Accessories section



Thermometer

Art. Nr.
5032240000107
5 units box



EXTRA 1 INOX

STAINLESS STEEL 316L CALORIFIER WITH 1 EXTRACTABLE STAINLESS STEEL HEAT EXCHANGER

STORAGE		HEAT EXCHANGER	
Pmax	Tmax	Pmax	Tmax
6 bar	95 °C	12 bar	110 °C

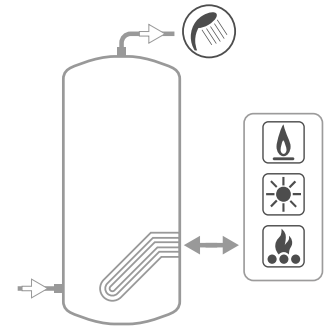
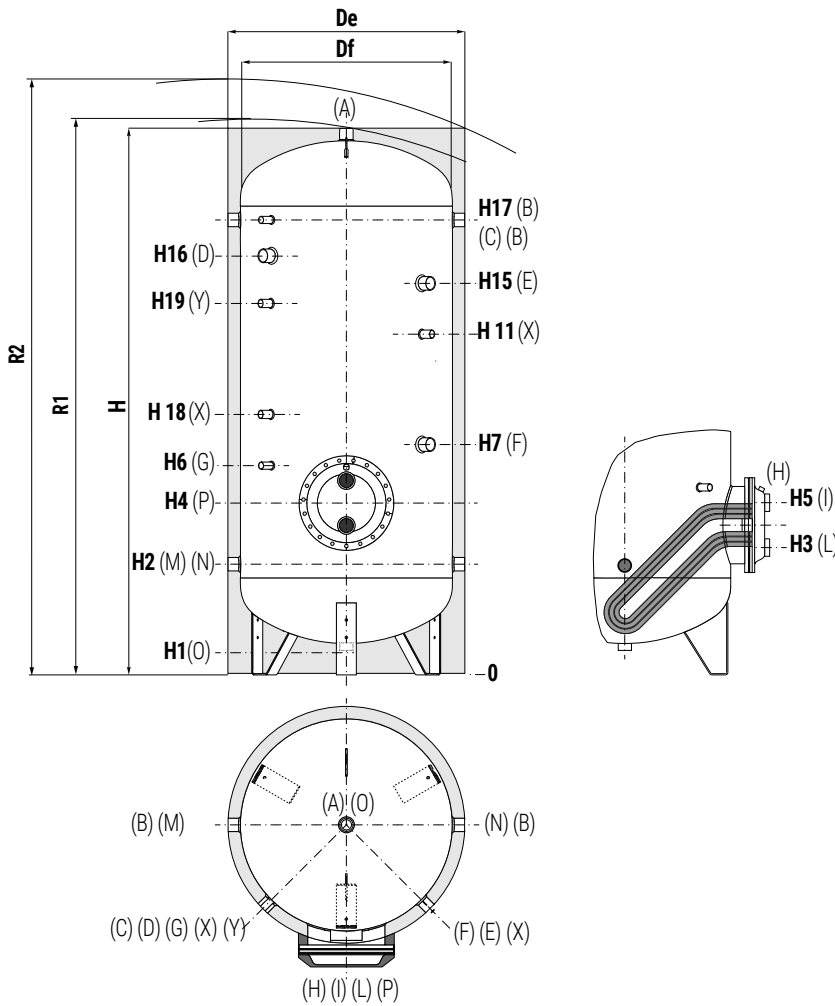

- A** Domestic hot water outlet
- B** Recirculation / Domestic hot water outlet
- C** Connection for instrumentation 1/2" G F
- D** Connection for electric immersion heater
- E** Connection for 2nd magnesium anode 1" 1/4 G F (only for models > 1500)
- F** Connection for magnesium anode/Titanium anode 1" 1/4 G F
- G** Connection for instrumentation 1/2" G F
- H** Heat exchanger drain 3/8" G F
- I** Primary circuit inlet
- L** Primary circuit outlet
- M** Domestic cold water circuit inlet
- N** Alternative domestic cold water circuit inlet or connection for more tanks
- O** DrainFor model 1000 Connection 1" 1/2 G F. For models > 1000 1" G F
- P** Flange
- X** Connection for titanium anode 3/4" G F (>1500)
- Y** Connection for titanium anode 3/4" G F (>3000)

Model	Volume [lt]	Weight [kg]	Df		De		De (vers. XXB)	H	R1	R2	H1	H2	H3	H4	H5	H6
			(vers. XXC)	(vers. XXC)	(vers. XXB)	(vers. XXB)										
200	192	57	//	//	550	1451	//	1552	81	316	351	401	451	511		
300	294	72	//	//	650	1569	//	1698	149	409	444	494	544	604		
500	504	98	//	//	750	1861	//	2006	141	426	461	511	561	621		
800	762	137	790	1010	//	1943	2008	2200	113	428	473	563	653	713		
1000	905	159	790	1010	//	2212	2270	2450	112	437	482	572	662	722		
1300	1277	199	950	1210	//	2193	2275	2510	118	433	578	668	758	818		
1500	1403	208	1000	1260	//	2177	2266	2530	112	447	592	682	772	832		
2000	2024	332	1250	1510	//	2099	2231	2600	134	529	649	754	859	929		
2500	2320	396	1250	1350	//	2299	2396	2680	134	529	649	754	859	929		
3000	2925	466	1250	1350	//	2799	2879	3120	134	529	709	814	919	989		
4000	3776	568	1400	1500	//	2872	2968	3250	117	557	737	842	947	1017		
5000	4995	734	1600	1700	//	2909	3031	3380	94	564	734	839	944	1014		

Model	H7	H11	H15	H16	H17	H18	H19	P
300	794	//	//	1159	1269	//	//	Ø1220/Øe300
500	811	//	//	1380	1536	//	//	Ø1220/Øe300
800	863	//	//	1382	1538	//	//	Ø1300/Øe380
1000	922	//	//	1642	1797	//	//	Ø1300/Øe380
1300	918	//	//	1638	1793	//	//	Ø1300/Øe380
1500	982	1522	//	1602	1757	1057	//	Ø1300/Øe380
2000	1004	//	1524	1473	1629	1159	//	Ø1300/Øe380
2500	954	1529	1794	1710	1879	1179	//	Ø1350/Øe430
3000	1014	1629	2294	2210	2369	1279	//	Ø1350/Øe430
4000	1022	1657	2302	2225	2397	1307	2090	Ø1350/Øe430
5000	1019	1664	2319	2159	2404	1314	2024	Ø1350/Øe430

O	BMN	LI	D	A
3/4"	1" 1/4	1"	1" 1/2	1" 1/4
3/4"	1" 1/4	1"	1" 1/2	1" 1/4
3/4"	1" 1/4	1"	1" 1/2	1" 1/4
3/4"	1" 1/4	2"	1" 1/2	1" 1/2
3/4"	1" 1/2	2"	2"	1" 1/2
1"	1" 1/2	2"	2"	2"
1"	1" 1/2	2"	2"	2"
1"	2"	2"	2"	2"
1"	2"	2"	2"	2"
1"	2"	2"	2"	2"
1"	2"	2"	2"	2"

P.E.D. product designed and produced in conformity to the article 4.3 of directive 2014/68/UE - ErP Ecodesign directive 2009/125/CE

EXTRA 1 INOX

HEAT EXCHANGERS TECHNICAL DATA



Data have been calculated on following basis:

- 1) Primary circuit at T1 and proper energy source;
- 2) Production of DHW in continuous from 10 °C to t2;
- 3) DHW that can be taken in the first 10' and in the first hour from storage at t2, input 10 °C and output 45 °C;
- 4) Non-scaling sanitary water

LOWER
HEAT EXCHANGER

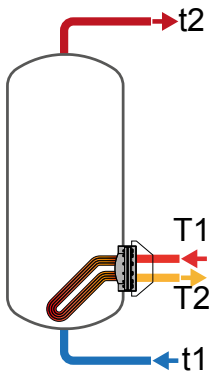

Model	Primary flow rate [m³/h]	Ignition time (minutes) from 10 °C to t2 and primary at T1				Maximum power exchange (kW) with primary at T1, secondary within 10-45 °C and constant use of DHW production				DHW continuous production lt/h within 10-45 °C and primary at T1			
		T1/t2				T1				T1			
		55/50	65/60	70/60	80/60	55	65	70	80	55	65	70	80
200	2	113	113	77	49	7,3	11,5	13,7	18	178	283	338	455
	1	147	148	102	65	5,8	8,9	10,5	13,9	141	218	258	344
300	3	112	113	76	48	11,1	17	21	28	274	435	520	701
	1,5	145	146	102	65	8,9	13,8	16,3	21,6	219	339	402	534
500	4	139	140	96	60	15	23,8	28,5	38	369	587	702	947
	2	180	181	125	80	12,1	18,7	22,1	29,4	297	460	545	725
800	6	146	147	101	64	23	36	44	59	570	908	1087	1465
	3	186	188	130	83	18	29	34	46	465	721	854	1136
1000	10	128	128	86	54	33	53	63	86	814	1309	1571	2127
	5	157	157	107,9	69	27	43	51	69	687	1077	1281	1711
1300	10	147	152	107	70	31	39	51	72	674	683	884	1253
	5	158	164	116	76	30	38	49	69	659	669	858	1201
1500	15	120	119	82	51	51	81	98	133	1256	2022	2428	3290
	7,5	145	146	100	64	44	68	81	108	1075	1687	2008	2684
2000	20	121	122	83	52	69	111	133	180	1699	2738	3288	4453
	10	146	147	101	65	59	93	111	148	1465	2302	2741	3665
2500	20	118	119	81	51	84	134	160	216	2066	3309	3964	5352
	10	145	146	101	65	71	111	131	174	1755	2734	3244	4314
3000	20	128	127	87	55	100	159	190	255	2461	3926	4694	6321
	10	456	157	110	70	84	130	154	204	2082	3224	3817	5053
4000	20	126	127	87	56	131	207	247	330	3236	5121	6105	8168
	10	159	161	112	73	110	168	198	260	2718	4151	4903	6443
5000	20	137	138	96	61	162	253	301	401	3992	6270	7450	9921
	10	176	179	125	82	135	204	239	312	3332	5049	5923	7727

Model	Primary flow rate [m³/h]	DHW produced in the first 10 minutes in lt/10' input 10 °C output 45 °C, storage at t2 and primary at T1				DHW produced in the first hour in lt/60' input 10 °C output 45 °C, storage at t2 and primary at T1				Heat exchanger pressure drop	
		T1/t2				T1/t2				[mmH ₂ O]	[mbar]
		55/50	65/60	70/60	80/60	55/50	65/60	70/60	80/60		
200	2	247	319	328	347	360	498	542	635	309	30,3
	1	241	308	314	329	330	446	478	547	84,74	8,3
300	3	371	480	494	524	545	755	823	968	372	36,5
	1,5	362	464	474	496	501	678	729	834	101,02	9,9
500	4	616	791	810	851	849	1162	1254	1450	419	41,1
	2	604	770	784	814	792	1061	1129	1273	113,381	11,1
800	6	998	1280	1310	1373	1359	1855	1998	2301	718	70,4
	3	980	1249	1271	1318	1275	1705	1812	2037	189,22	18,6
1000	10	1273	1640	1683	1776	1788	2469	2678	3123	1380	135,3
	5	1252	1601	1635	1707	1687	2283	2446	2790	358,5	35,2
1300	10	1572	1938	1972	2033	1999	2006	2167	2462	1380	135
	5	1569	1936	1967	2024	1987	1995	2146	2420	358	35
1500	15	1855	2394	2462	2605	2651	3675	4000	4689	2295	225,1
	7,5	1825	2338	2392	2504	2506	3407	3664	4204	589,6	57,8
2000	20	2546	3285	3377	3571	3622	5019	5459	6391	2996	293,8
	10	2507	3212	3285	3439	3435	4670	5021	5761	766,42	75,2
2500	20	2988	3856	3965	4196	4296	5951	6475	7586	2436	238,9
	10	2936	3760	3845	4023	4047	5491	5899	6755	624	61,2
3000	20	3748	4827	4955	5226	5307	7314	7928	9230	2836	278,1
	10	3685	4710	4809	5015	5004	6752	7226	8215	723	70,9
4000	20	4842	6232	6396	6740	6892	9475	10263	11913	3896	382,1
	10	4756	6070	6196	6452	6477	8699	9301	10533	989	97,0
5000	20	6362	8166	8363	8775	8891	12137	13081	15058	4707	461,6
	10	6252	7963	8109	8409	8363	11161	11860	13303	1192	116,9

MAXIMUM STORAGE EXPLOITATION WITH CURVED ANTILEGIONELLA® HEAT EXCHANGER



Model	Heated volume: Standard heat exchanger	Storage volume: Heat exchanger for 100% heated volume	Advantage in exploited volume	Advantage in percentage
	[lt]	[lt]	[lt]	[%]
200	165	190	25	13%
300	251	285	34	12%
500	438	485	47	10%
800	680	750	70	10%
1000	800	900	100	13%
1300	1150	1260	110	10%

Model	Heated volume: Standard heat exchanger	Storage volume: Heat exchanger for 100% heated volume	Advantage in exploited volume	Advantage in percentage
	[lt]	[lt]	[lt]	[%]
1500	1224	1445	221	15%
2000	1684	1978	294	15%
2500	1905	2315	410	18%
3000	2438	2921	483	17%
4000	3113	3769	656	17%
5000	4116	4982	866	17%

EXTRA 1 INOX

HEAT EXCHANGERS PRESSURE DROP



Lower heat exchanger surface [m ²]	
200	0,5
300	0,75
500	1,5
800	2
1000	3
1300	3
1500	3
2000	4
2500	5
3000	6
4000	8
5000	10

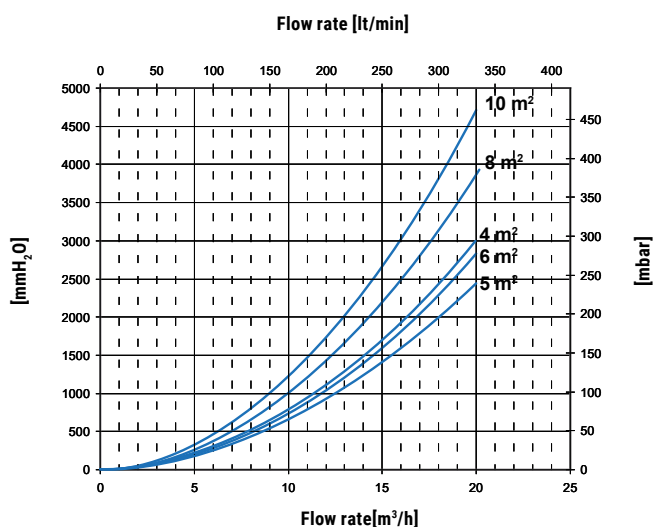
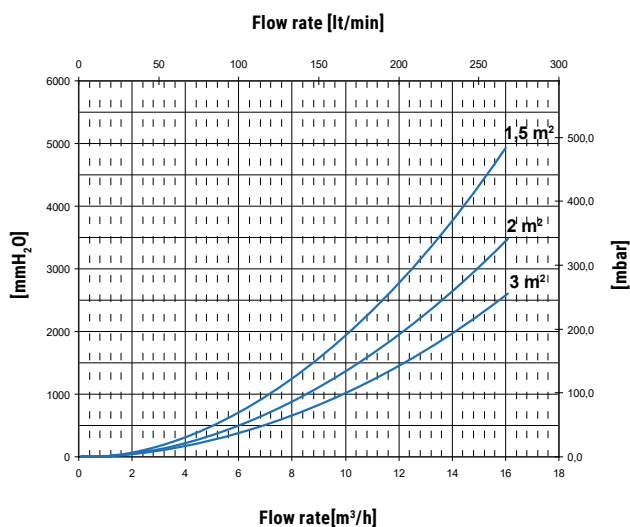
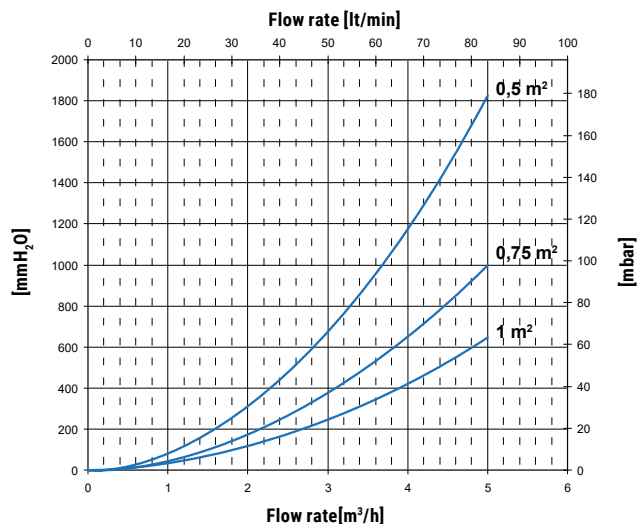

EXAMPLE OF INSTALLATION WITH EXTRA 1 INOX

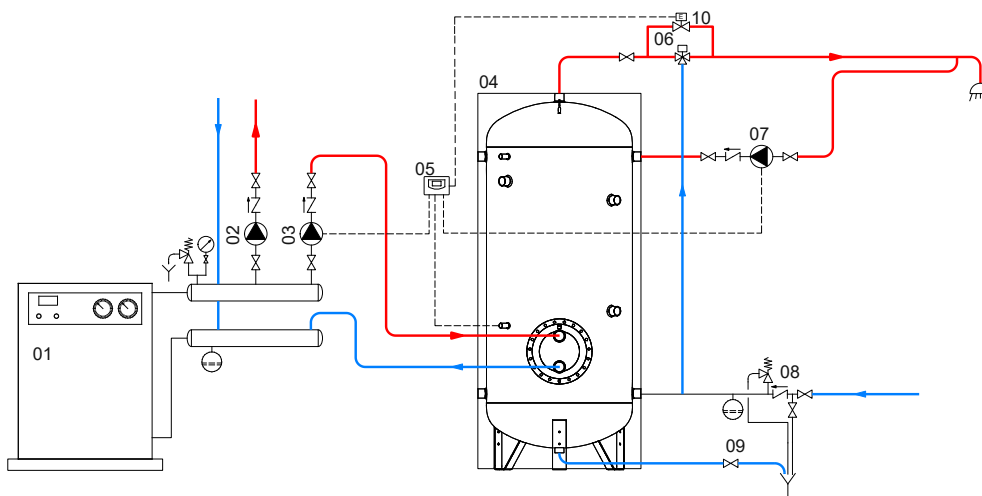

1	Generator	4	EXTRA 1 INOX	7	D.H.W. recirculation group	10	By-pass solenoid valve
2	Heating system circulation group	5	Electronic Control/thermostat	8	Hydraulic safety group		
3	D.H.W. circulation group	6	Thermostatic mixing valve	9	Blowdown valve		

The following schemes are purely illustrative. To realize the installation, always refer to a qualified technician.

EXTRA 1-2-3 WXC-XXC / EXTRA 1 COMPACT

HEAT EXCHANGERS TECHNICAL DATA

Heat Exchanger output referred to temperature and flow rate of primary circuit and with secondary at 10/45°C at maximum withdrawal of producible DHW (Upper limit of the curves referred to maximum primary flow rate in the heat exchanger, while the lower limit in the curves refer to the minimum primary flow rate)

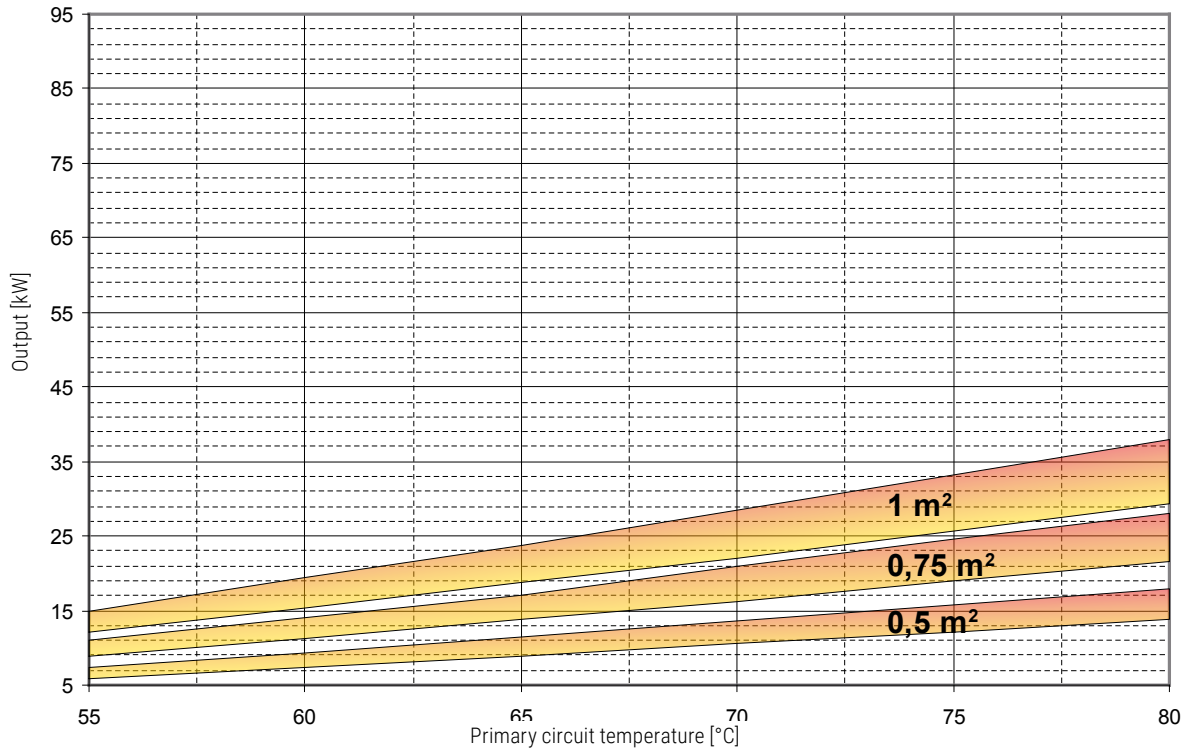
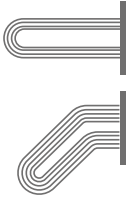

Extractable heat exchanger surface	0,5 m ²		0,75 m ²		1 m ²	
	MAX	MIN	MAX	MIN	MAX	MIN
Flow rate [m ³ /h]	2	1	3	1,5	4	2

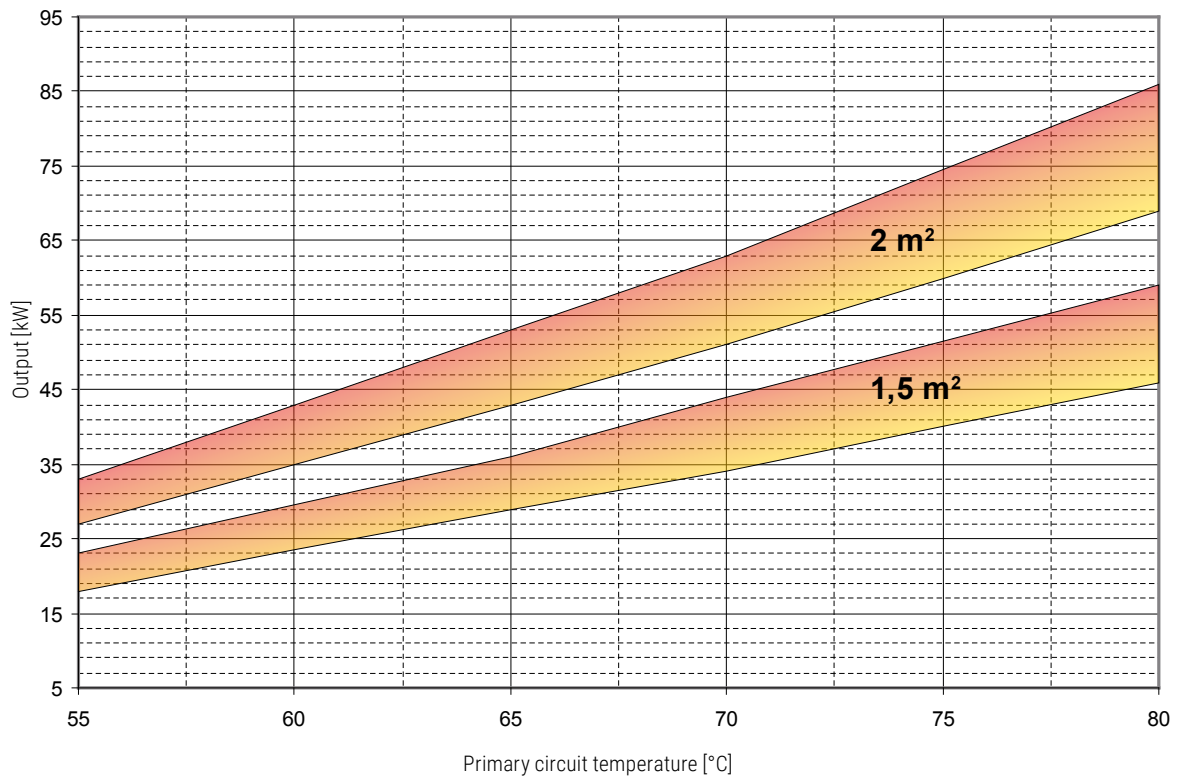
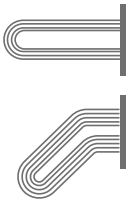

Extractable heat exchanger surface	1,5 m ²		2 m ²	
	MAX	MIN	MAX	MIN
Flow rate [m ³ /h]	6	3	10	5

EXTRA 1-2-3 WXC-XXC / EXTRA 1 COMPACT

HEAT EXCHANGERS TECHNICAL DATA

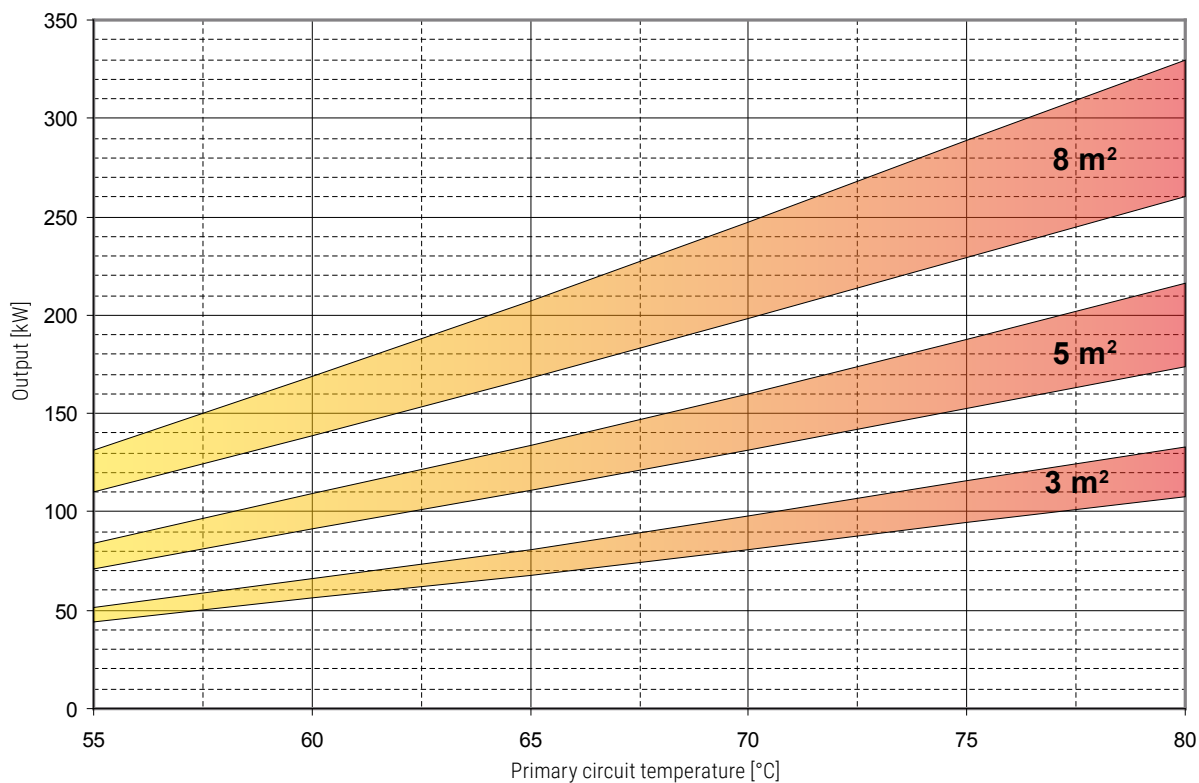

Extractable heat exchanger surface	3 m ²		5 m ²		8 m ²	
	MAX	MIN	MAX	MIN	MAX	MIN
Flow rate [m ³ /h]	15	7,5	20	10	20	10

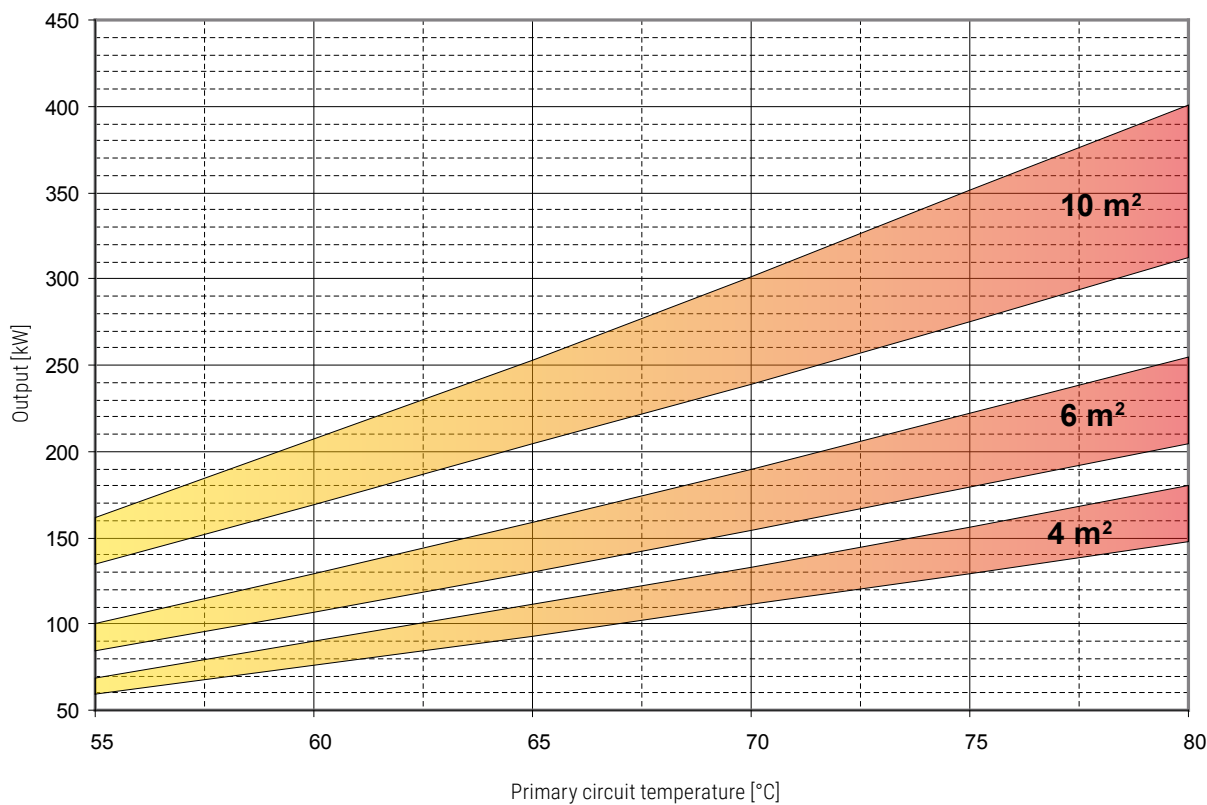

Extractable heat exchanger surface	4 m ²		6 m ²		10 m ²	
	MAX	MIN	MAX	MIN	MAX	MIN
Flow rate [m ³ /h]	20	10	20	10	20	10