

ECO-COMBI 1 DOMUS

MULTI-HEAT ENERGY BUFFER WITH STAINLESS STEEL 316L D.H.W. CORRUGATED COIL



APPLICATION

Heating hot water storage and rapid D.H.W. production.

MATERIAL

- BUFFER TANK: Mild steel painted on the outside. Buffer intended for closed circuit installation, so no anti-corrosion treatment is provided.
- D.H.W. STORAGE : Stainless steel 316L corrugated coil, suitable for D.H.W. according to D. M. n. 174 dated 06.04.04

TECHNICAL DESCRIPTION

Multi-Heat Energy tanks EcoCombi 1 Domus are used in units with a typically discontinuous energy source for double use: heating system and domestic hot water systems.

- Thermal storage, combining the possibility to produce hot water for sanitary use. In such case, storage heating volume allows the generator to regularly work, limiting number of stops due to the inadequate energy request of the heating systems. Moreover, it limits the emission of smoke and the creation of corrosive condensate (smoke side).
- Domestic hot water production system for domestic and sanitary use where heating water is stored. In this system, the high potentiality of the Eco Combi allows to obtain a good production of hot sanitary water even if temperatures of the primary system are not so high (i.e using heat pumps as primary source and solar source as support).

The particular shape of the corrugated pipe avoids any problem relating to the storage of domestic hot water and ensures high heat exchange performances.

INSULATION

High thermal insulation with ecological hard polyurethane foam. Grey PVC external lining complete with top cover.

WARRANTY

5 years (See general sales conditions and warranty)

ACCESSORIES AND SPARE PARTS

See Accessories section for the entire list.



316L STAINLESS STEEL D.H.W. CORRUGATED COIL



PROMPT AVAILABILITY



ECO-COMBI 1 DOMUS VB

316L STAINLESS STEEL CORRUGATED COIL FOR D.H.W. PRODUCTION

ENERGY EFFICIENCY CLASS

Model	HARD FOAM INSULATION Art. Nr.	316L STAINLESS STEEL CORRUGATED COIL FOR D.H.W. PRODUCTION		ErP ENERGY EFFICIENCY CLASS
		Volume [lt]	Surface [m ²]	
200	3270162316021	2,9	1,4	B
300	3270162316022	5,1	2,5	B

Model	Max sanitary water produced from 10°C to 45°C with storage at 60°C	Max sanitary water produced from 10°C to 45°C with storage at 50°C
	[lt/min]	[lt/min]
200	11	8
300	23	16

ACCESSORIES

Electric immersion heaters

	
Available kit:	
[Kw]	Tension [V]
from 1,5 to 3	220 - MONOPHASE
See accessories	

Thermometer

Art. Nr.	
5032240000107	
5 units box	

ECO-COMBI 1 DOMUS

MULTI-HEAT ENERGY BUFFER WITH STAINLESS STEEL 316L D.H.W. CORRUGATED COIL

STORAGE		CORRUGATED DHW STAINLESS STEEL 316L COIL
Pmax	Tmax	Pmax
3 bar	99 °C	6 bar

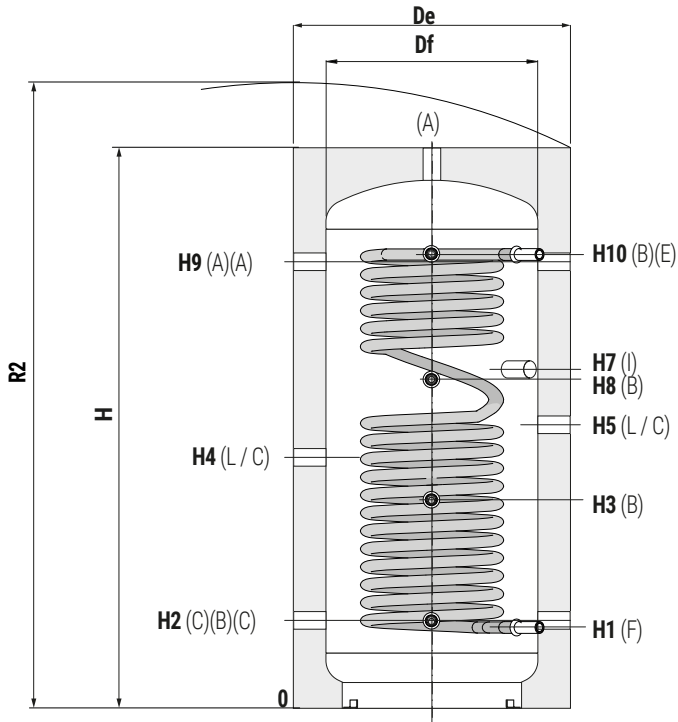
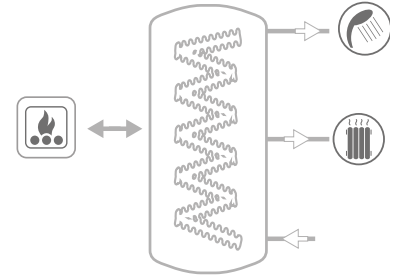

A	Heating delivery/From generator/Air purge 1*1/2 G F
B	Probe 1/2" G F
C	Heating return/to generator
E	Domestic hot water outlet 1/2" G F
F	Domestic cold water circuit inlet 1/2" G F
I	Connection for electric immersion heater 1*1/2 G F
L	Heating delivery 1*1/2 G F

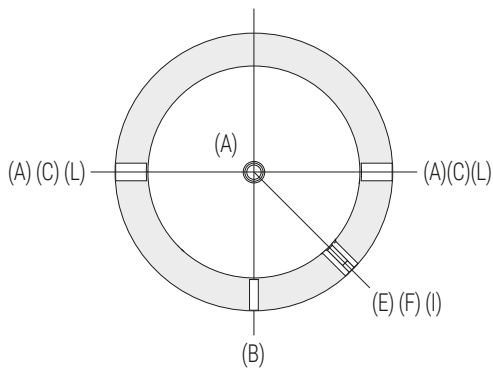

P.E.D. product designed and produced in conformity to the article 4.3 of directive 2014/68/UE - ErP Ecodesign directive 2009/125/CE

Model	Volume [lt]	DE	H	R2	H1	H2	H3	H4	H5	H7	H8	H9	H10
		[mm]											
200	180	590	1310	1445	227	252	552	602	702	852	822	1052	1079
300	279	690	1360	1530	257	272	572	622	722	872	812	1072	1084