

COMBI 2 INOX

MULTI-HEAT ENERGY BUFFER WITH STAINLESS STEEL 316L TANK IN TANK CALORIFIER AND 1 FIXED HEAT EXCHANGER



APPLICATION

Heating hot water storage and D.H.W. production.

MATERIAL

Buffer tank: Mild steel, painted externally and untreated internally.

D.H.W. storage: Stainless steel 316L suitable for D.H.W.

HEAT EXCHANGER:

Nr. 1 fixed heat exchanger.

TECHNICAL DESCRIPTION

Multi-Heat Energy tanks Combi 2 are used in units with a typically discontinuous energy source for double use: heating systems and domestic hot water systems.

INSULATION

High thermal insulation with ecological polyurethane hard foam.

Grey PVC external lining.

CATHODE PROTECTION

Chain magnesium anode

WARRANTY

5 years (See general sales conditions and warranty)

ACCESSORIES AND SPARE PARTS

See Accessories section for the entire list.



316L
STAINLESS STEEL
DHW STORAGE



COMBI 2 XB

Model	HARD FOAM INSULATION Art. Nr.	STAINLESS STEEL 316L DHW STORAGE		FIXED HEAT EXCHANGER		ENERGY EFFICIENCY CLASS
		Volume [lt]	Surface [m ²]	Volume [lt]	Surface [m ²]	
500	3270162314151	99	1,1	11,5	1,9	C
600	3270162314152	146	1,3	18	2,8	C



Model	DISMOUNTABLE HARD FOAM INSULATION Art. Nr.	STAINLESS STEEL 316L DHW STORAGE		FIXED HEAT EXCHANGER		ENERGY EFFICIENCY CLASS
		Volume [lt]	Surface [m ²]	Volume [lt]	Surface [m ²]	
800	3270162314153	191	1,6	20	3,1	C
1000	3270162314154	226	1,8	24	3,7	C

ACCESSORIES

Thermometer

Art. Nr.	
5032240000107	
5 units box	

Chain magnesium anode (Connection 3/4")

Art. Nr.	For models	
5200000041007	800,1000	
5200000041016	500,600	
N° 2 chain anodes + insulated cap + gasket		

Buffer tanks connecting kit

Art. Nr.	Connection	
5006170001001	1" 1/2	
Stainless steel extensible connecting kit - (200 ÷ 400 mm)		

COMBI 2 INOX

MULTI-HEAT ENERGY BUFFER WITH STAINLESS STEEL 316L TANK IN TANK CALORIFIER AND 1 FIXED HEAT EXCHANGER

TECHNICAL STORAGE		D.H.W. STORAGE		FIXED HEAT EXCHANGER	
Pmax	Tmax	Pmax	Tmax	Pmax	Tmax
3 bar	99 °C	6 bar	95 °C	12 bar	110 °C

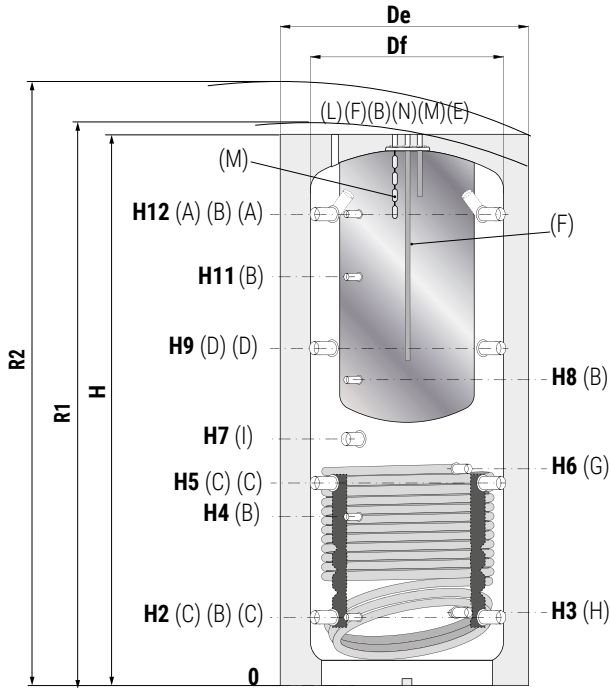
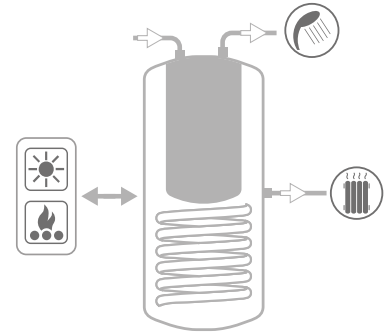

- A** Heating delivery/From generator 1"1/2 G F
- B** Connection for instrumentation 1/2" G F
- C** Heating return/to generator 1"1/2 G F
- D** Heating delivery 1"1/2 G F
- E** Domestic hot water outlet 3/4" G F
- F** Domestic cold water circuit inlet 3/4" G F
- G** Fixed heat exchanger inlet 1" G F
- H** Fixed heat exchanger outlet 1" G F
- I** Connection for electric immersion heater 1"1/2 G F
- L** Air purge 1/2" G F
- M** Connection for magnesium anode 3/4" G F
- N** Recirculation 3/4" G F

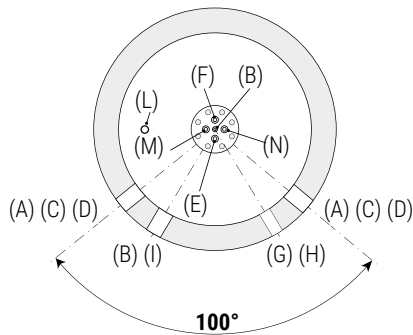

Model	Volume [lt]	Weight [kg]	Df	De	H	R1	R2	H2	H3	H4	H5	H6	H7	H8	H9	H11	H12
			[mm]														
500	478	105	//	750	1650	//	1820	247	260	533	629	744	841	940	1011	1231	1343
600	560	122	//	750	1900	//	2050	247	260	582	695	855	915	1060	1144	1382	1593
800	805	140	790	950	1855	2030	2090	265	278	584	690	762	823	988	1115	1332	1541
1000	946	201	790	950	2160	2310	2370	265	284	656	787	953	998	1188	1309	1588	1831

P.E.D. product designed and produced in conformity to the article 4.3 of directive 2014/68/UE - ErP Ecodesign directive 2009/125/CE

COMBI 2 INOX

D.H.W. STORAGE PERFORMANCES



Model	COMPLETE HEATED STORAGE VOLUME			UPPER PART HEATED STORAGE VOLUME		
	DHW Volume	DHW exchanger surface	Max flowrate of sanitary water sustained from 10°C to 45°C with storage at 65°C and boiler on	Max sanitary water produced from 10°C to 45°C with storage at 65°C and boiler off	Max flowrate of sanitary water sustained from 10°C to 45°C with storage at 65°C and boiler on	Max sanitary water produced from 10°C to 45°C with storage at 65°C and boiler off
	[lt]	[m ²]	[lt/min]	[lt]	[lt/min]	[lt]
500	99	1,1	2,5	10 lt/min: 198 lt 25 lt/min: 176 lt	1,57	10 lt/min: 148 lt 25 lt/min: 132 lt
600	146	1,3	3,0	10 lt/min: 239 lt 25 lt/min: 213 lt	1,86	10 lt/min: 179 lt 25 lt/min: 160 lt
800	191	1,6	3,5	10 lt/min: 320 lt 25 lt/min: 280 lt	2,17	10 lt/min: 240 lt 25 lt/min: 210 lt
1000	226	1,8	4,1	10 lt/min: 389 lt 25 lt/min: 330 lt	2,26	10 lt/min: 291 lt 25 lt/min: 250 lt

LOWER HEAT EXCHANGERS PRESSURE DROP

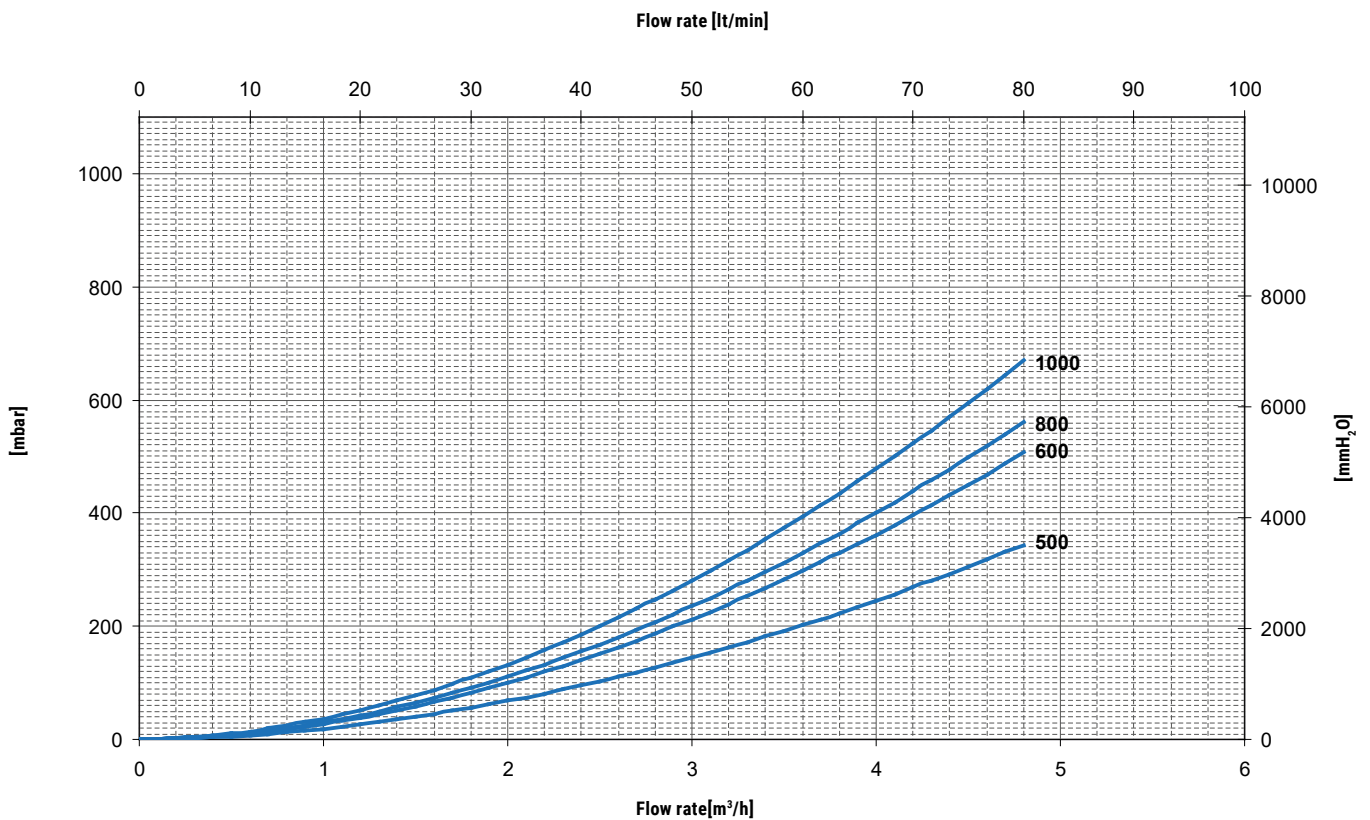

COMBI 2 INOX

LOWER HEAT EXCHANGERS TECHNICAL DATA



Output of the Combi 2 lower heat exchangers depending on the average DeltaT between primary and accumulation considering flow rate 3 m³/h.

Thermal output is given in both kW or kcal/h in terms of average temperature difference between primary and secondary circuit, all for a range of primary 3 m³/h. For example, a 1000 liters COMBI 2 with a water flow of 3 m³/h at 80 °C inlet and outlet at 70 °C, has on the storage of water an average temperature of 60 °C, the main difference of temperature will be: $(80 + 70) / 2 - 60 = 15$ °C and therefore you can exchange up to approximately 32 kW.

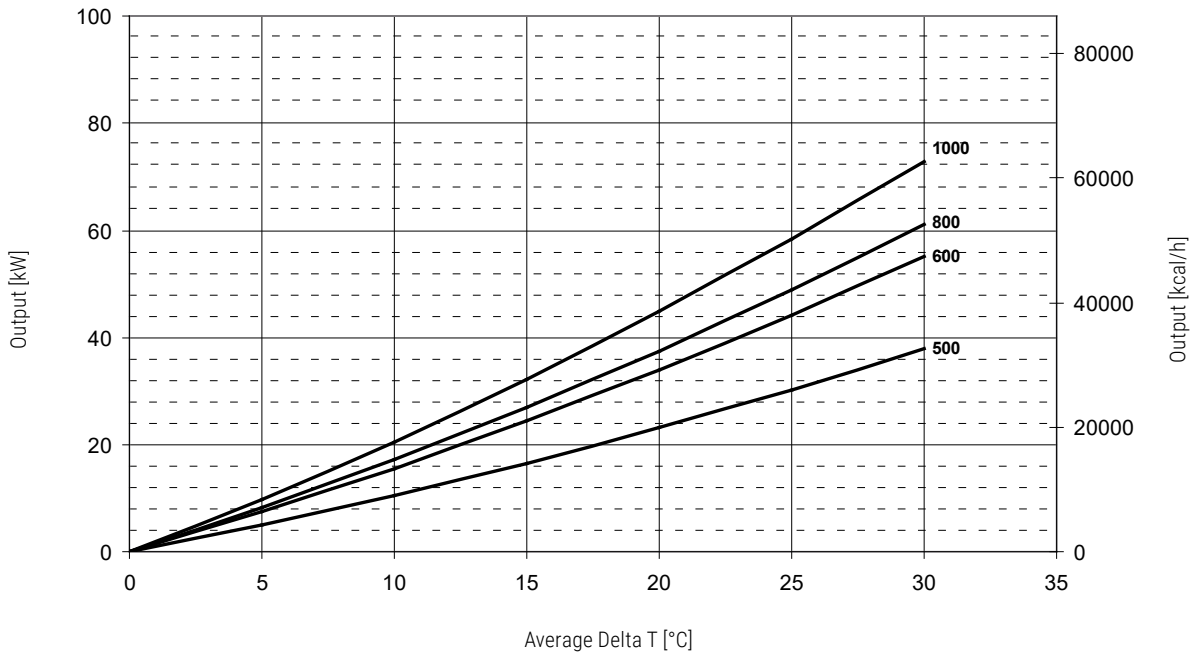

EXAMPLE OF INSTALLATION WITH COMBI 2 INOX

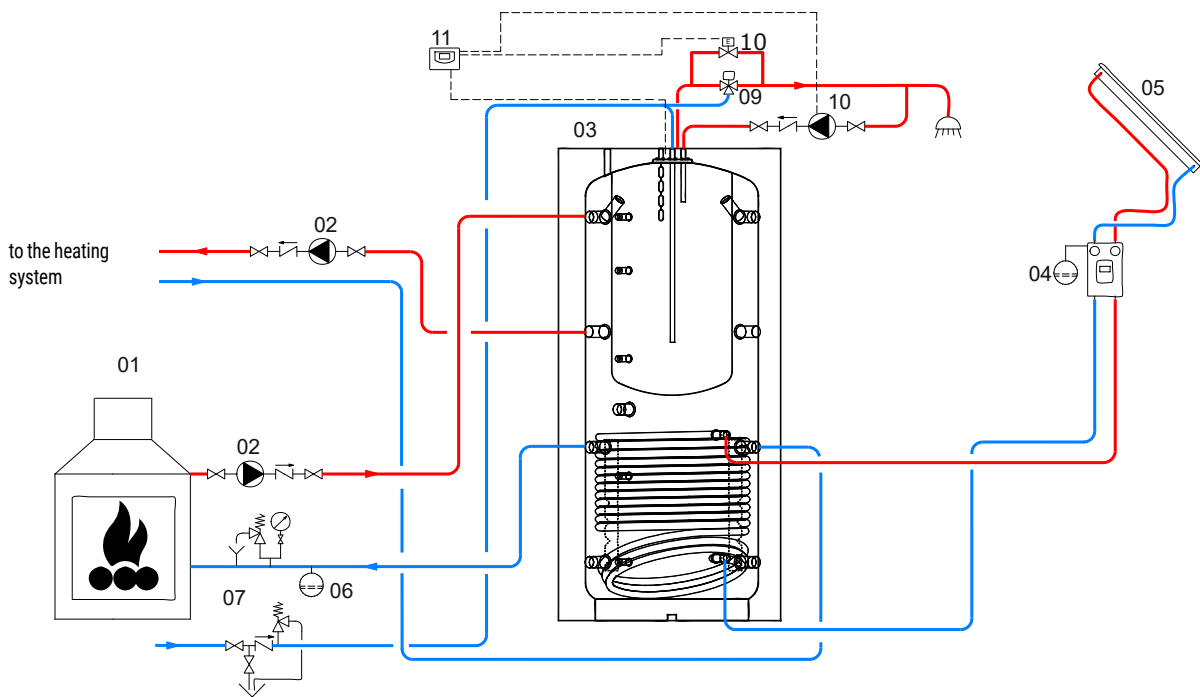

01	Generator	04	Solar system circulation group	07	Hydraulic safety group	10	By-pass solenoid valve
02	Heating system circulation group	05	Solar panels	08	D.H.W. recirculation group	11	Electronic Control/thermostat
03	COMBI 2	06	Expansion vessel	09	Thermostatic mixing valve		

The following schemes are purely illustrative. To realize the installation, always refer to a qualified technician.